



PV = Process value
SV = Set value

TECHNICAL SPECIFICATION

INPUT SPECIFICATION:

Input Types	Input	Range
	J	0 to 400 °C
	K	0 to 500 °C
	1 CT	0.0 to 60.0 A
Resolution	J,K = 1 °C	
Indication Accuracy	±1% of FSD ± 1 °C (FSD:- full scale deflection)	

DISPLAY AND KEYS:

Display	Upper: 3 digit, 7 seg 0.70" white LED Middle: 3 digit, 7 seg, 0.39" green LED Lower: 3 digit, 7 seg, 0.33" red LED
Keys	SET, INC, DEC, ENT

DIMENSION:

Size (mm)	72 (H) x 72 (W) x 85 (D) mm
Panel Cutout	68 (H) x 68 (W) mm

CONTROL METHOD:

Heating	1) PID control with Auto-Tuning 2) ON-OFF control
Cooling	1) BL.TP (Blower Time Proportion) 2) ON-OFF control
Alarm	Heater break alarm, Cold start, High, Absolute low, Inband, Absolute outband, OFF, Outband, Low

OUTPUT SPECIFICATION:

Relay Output	
Relays	2 Nos
Relay Type	1 st Relay 1C/O (NO-C-NC) , 2 nd Relay (NO-C)
Rating	10A,230V AC/28V DC
SSR Drive Output	
Output Signal	24V DC, 30mA DC (On-Off condition)

POWER SUPPLY:

Supply Voltage	100 to 270V AC, 50-60Hz
Power Consumption (VA Rating)	Approx 6VA @ 230V AC

ENVIRONMENT CONDITION:

Operating Temp.	0 °C to 55 °C
Relative Humidity	UP to 95% RH (non-condensing)
Protection Level	IP-65 (Front side) As per IS/IEC 60529 : 2001

MECHANICAL INSTALLATION

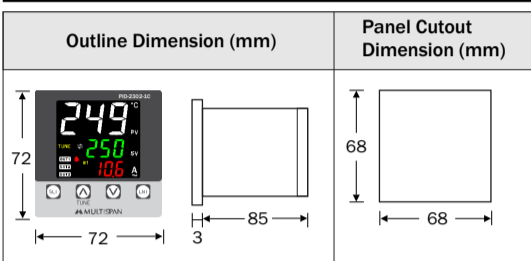

TERMINAL CONNECTION

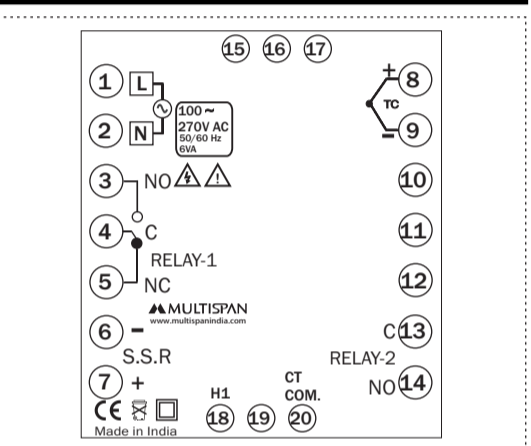

STATUS LED DESCRIPTION

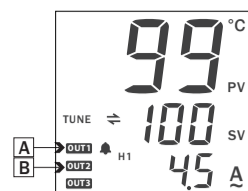

A - Control output 1 indication (Heating)
B - Control output 2 indication (Cooling / Alarm)

KEY OPERATION

FUNCTION	PRESS KEY
OPERATOR MODE	
To enter in parameter setting	Press SET for 4 sec
For start/stop PID auto tuning	Press TUNE for 6 sec
To go in factory setting mode	TUNE + ENT Press 3 sec
PARAMETER SETTING MODE	
To set parameter value	SET
To increment parameter value.	TUNE
To decrement parameter value.	ENT
Set parameter to be save & exit.	ENT

SAFETY PRECAUTION

All safety related codifications, symbols and instructions that appear in this operating manual or on the equipment must be strictly followed to ensure the safety of the operating personnel as well as the instrument.

If all the equipment is not handled in a manner specified by the manufacturer, it might impair the protection provided by the equipment.

Read complete instructions prior to installation and operation of the unit.

WARNING : Risk of electric shock.

WARNING GUIDELINES

WARNING : Risk of electric shock.

- To prevent the risk of electric shock power, supply to the equipment must be kept OFF while doing the wiring arrangement. Do not touch the terminals while power is being supplied.
- To reduce electro magnetic interference, use wire with adequate rating and twists of the same of equal size shall be made with shortest connection.
- Cable used for connection to power source, must have a cross section of 1mm or greater. These wires should have insulations capacity made of at least 1.5kV.
- When extending the thermocouple lead wires, always use thermocouple compensation wires for wiring for the RTD type, use a wiring material with a small lead resistance (5Ω max per line) and no resistance differentials among three wires should be present.
- A better anti-noise effect can be expected by using standard power supply cable for the instrument.

INSTALLATION GUIDELINES

- This equipment, being built-in-type, normally becomes a part of main control panel and in such case the terminals do not remain accessible to the end user after installation and internal wiring.
- Do not allow pieces of metal, wire clippings, or fine metallic fillings from installation to enter the product or else it may lead to a safety hazard that may in turn endanger life or cause electrical shock to the operator.
- Circuit breaker or mains switch must be installed between power source and supply terminal to facilitate power 'ON' or 'OFF' function. However this mains switch or circuit breaker must be installed at convenient place normally accessible to the operator.
- Use and store the instrument within the specified ambient temperature and humidity ranges as mentioned in this manual.

MECHANICAL INSTALLATION GUIDELINES

- Prepare the panel cutout with proper dimensions as shown above.
- Fit the unit into the panel with the help of clamp given.
- The equipment in its installed state must not come in close proximity to any heating source, caustic vapors, oil steam, or other unwanted process byproducts.
- Use the specified size of crimp terminal (M3.5 screws) to wire the terminal block. Tightening the screws on the terminal block using the tightening torque of the range of 1.2 N.m.
- Do not connect anything to unused terminals.

MAINTENANCE

- The equipment should be cleaned regularly to avoid blockage of ventilating parts.
- Clean the equipment with a clean soft cloth. Do not use isopropyl alcohol or any other cleaning agent.
- Fusible resistor must not be replaced by operator.

ERROR DISPLAY

When an error has occurred the display indicates error codes as given below.

ERROR	MEANING
OPn	Sensor is not connected or Over range condition or sensor break
SrE	Sensor connection is reversed

CORRECTIVE ACTION:

Check the sensor and the input wiring. If problem still exists, replace the sensor. And still if problem is not solved yet by the user, then please contact company person

FACTORY SETTING

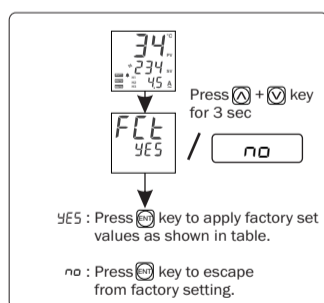

SR.	PARAMETER	VALUES
1	PB	20.0 °C
2	IT	300
3	DT	75
4	CT	15 Sec
5	MR	0 °C
6	C-PB	4.0
7	C-ON	1 Sec
8	C-OFF	48 Sec
9	Hysteresis1	3 °C
10	Hysteresis 2	1 °C
11	Hysteresis 3	3 °C
12	Alarm Time R2	5 Sec
13	Alarm Time R3	5 Sec
14	Offset	0 °C

PARAMETER MESSAGE DESCRIPTION

Parameter	Description
i nP	Input
J	J
K	K
r lñ	Relay 1 Mode
HEE	Heating
Pi d	PID Action
OnF	ON-OFF Action
HYS 1	Hysteresis 1
r2ñ	Relay 2 Mode
COl	Cooling
b.tP	Blower TP Action
HYS 2	Hysteresis 2
ALñ	Alarm
HbA	Heater Break Alarm
CS	Cold Start Alarm
Hi 9	High Alarm
AbL	Absolute Low Alarm
L0!	Low
Obb	Outband
i nb	In Band Alarm
AbO	Absolute Outband Alarm
t lñ	Time
HbA	Heater Break Alarm Set Point
Hb	Heater Break Indication Set Point
H	Heater
On	ON
OFF	OFF
Pb	Proportional Band for PID Action
It	Integral Time for PID Action
dt	Derivative Time for PID Action
Ct	Cycle Time for PID Action
ñr	Manual Reset for PID Action
C. Pb	Cooling Proportional Band
C. On	Cooling ON
C. OF	Cooling OFF
PAR	Parameter
PAS	Password
rLt	Relative
i nd	Individual
SE 1	Set 1
SE 2	Set 2
SE2L0!	Set 2 Low
SE2Hi 9H	Set 2 High
OFFS	Offset
OPñ	Output Mode
b.tH/r.LY/SSr	Both/Relay/SSR

WORKING

- R1-Heating**
- Control Mode PID: Relay turning ON/OFF according to heat requirement of the machine.
 - Control Mode ON/OFF: Relay turns ON (and remains ON) when PV < SV. Relay turns OFF when PV > SV. After this there may be overshoot depending on the thermal inertia of the machine. When the PV < SV Minus HYS, Relay turns ON and heating is resumed.
- R2-Cooling**
- Cooling Time proportional Control action: Relay turns ON/OFF as per et Cycle timeand difference between PV and cooling SV.
 - Cooling ON/OFF control action: Relay is initially OFF. When PV > SV, Relay turns ON and when PV < SV Minus HYS relay turns OFF.
- Auto Tuning:-**
- The Auto-tuning function automatically computes and sets the Proportional band (Pb) , Integral time (It), Derivative time (dt), and cycle time as per process characteristics.
 - Tuning LED will turn "ON" during Auto-Tuning
 - If the power goes off before auto-tuning is completed, auto-tuning will be restarted at next power ON.

PARAMETER RANGE

Parameter	Range For J, K
PB	0.0 °C to 999.9 °C
IT	0 to 9999
DT	0 to 9999
CT	4 sec to 99 sec
MR	-9 to +9
C.PB	2.0 °C to 25.0 °C
C.ON	1 to 20
C.OF	5 to 200
Alarm Time R2	0 Sec to 99 Sec
Hysteresis-1	1 °C To 100 °C
Hysteresis-2	1 °C to 50 °C
Set 2	1 °C to 50 °C
Offset	-20 °C to 20 °C
HBAL/HBI H	0.0 to 60.0A
Set 2	R2MD = CS S2MD = RLT -50 to 0
	R2MD = IND S2MD = IND 0 to set 100
Set 2 Low	R2MD = HIG S2MD = RLT -50 to +50
	LOW/ABL S2MD = IND SLL to SHL
Set 2 High	SET2 LOW To SHL

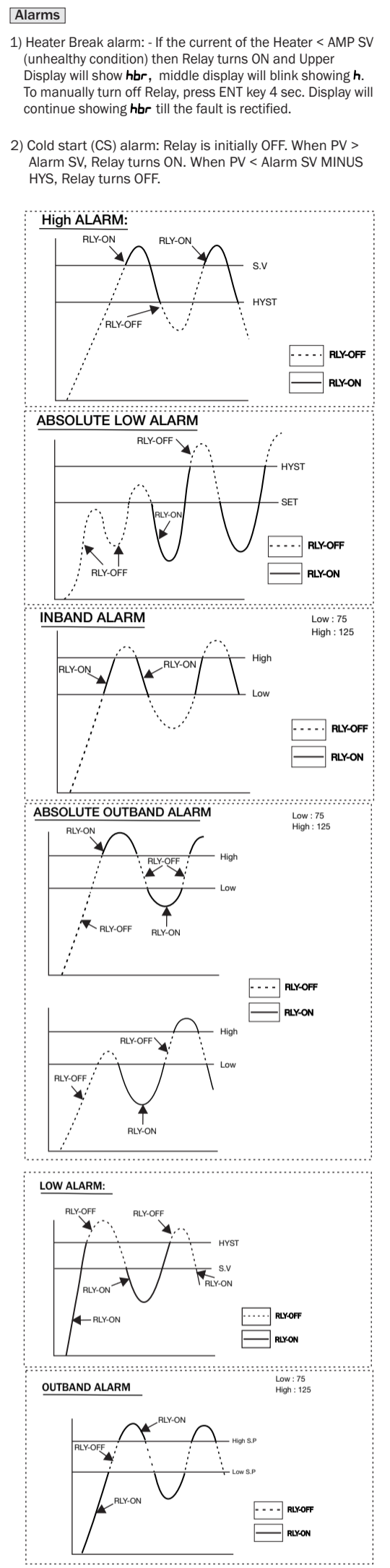
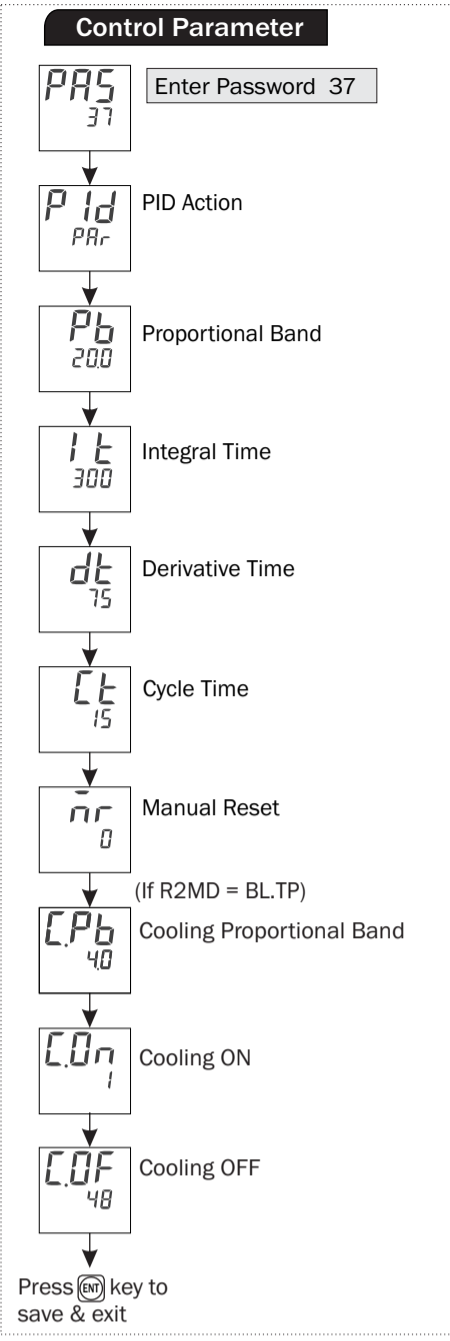
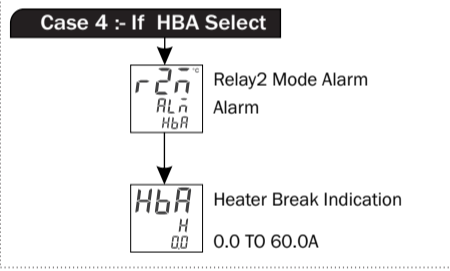
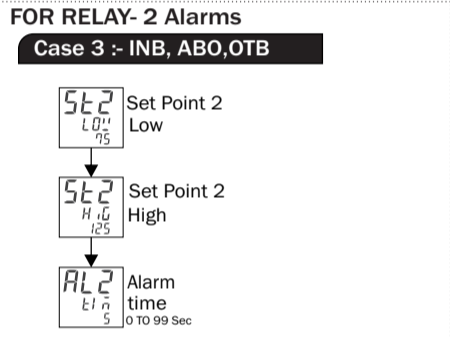
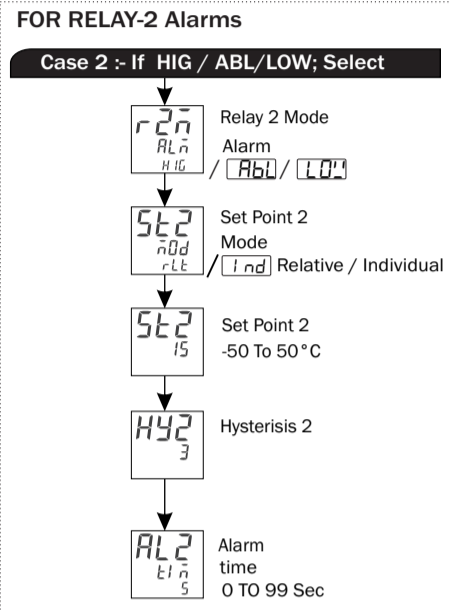
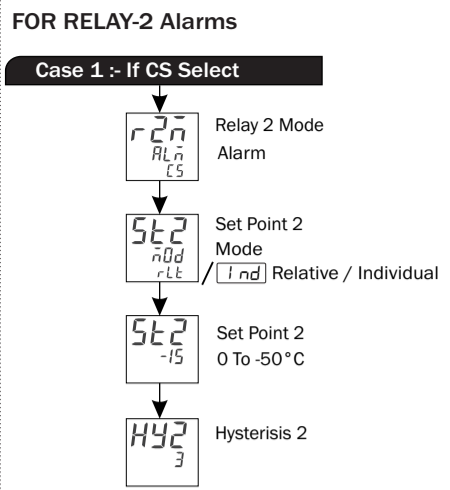
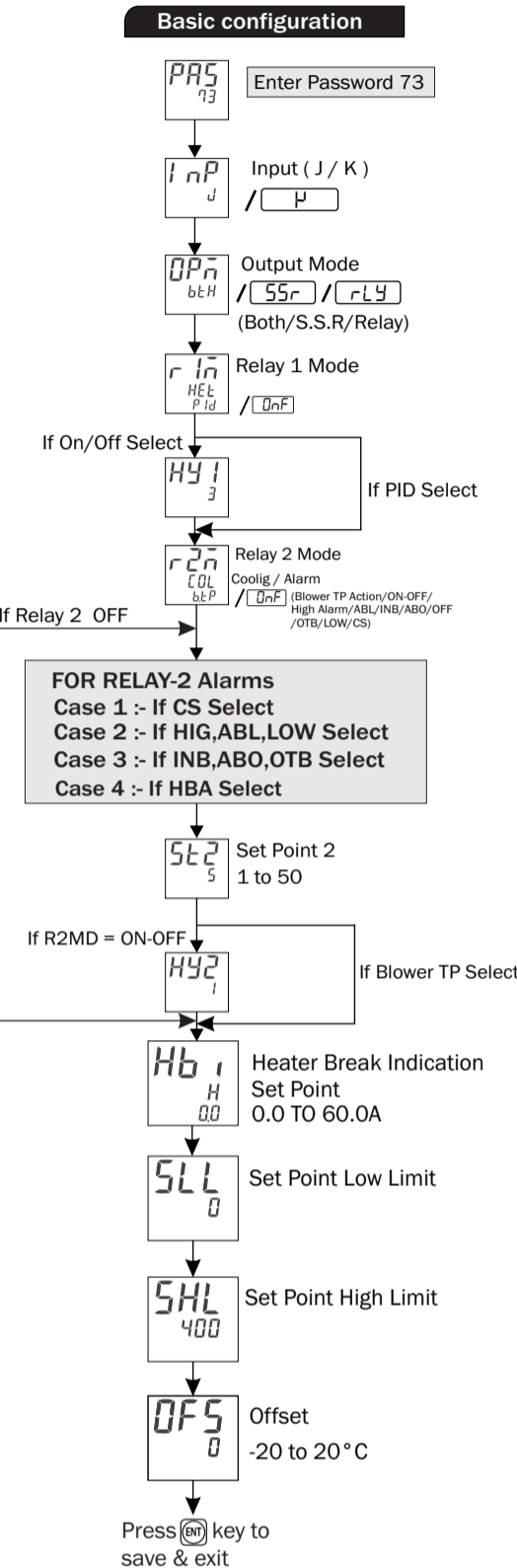
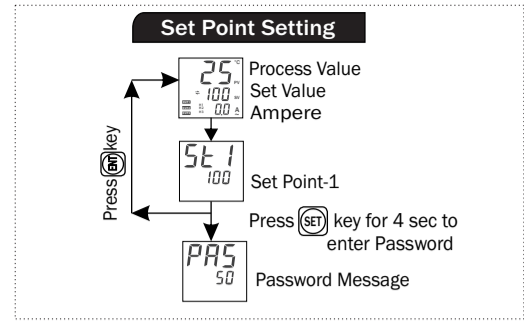

Specifications are subject to change since development is a continuous process. For more updated operating information and support call 011-689-5700. Ver2109