

EMT 1900 is an easy to mount LCD digital panel meter. The module can measure ambient temperature via a built-in sensor and outside temperature via an external sensor (not supplied). The module uses NTC temperature sensors to ensure high accuracy over a wide temperature range. To mount the module, the user need only drill a single 5.5mm /  $\frac{7}{32}$ " hole in the panel. The module is fitted to the panel by locating its screw threaded stud through the hole, fitting the washer and tightening the nut provided. The module's connecting wires pass through the hollow stud into the target application, where they can be easily plugged or soldered into place. A rubber seal is included, providing splashproof protection for the unit when fitted to the meter during installation.

- 🔍 Single Hole Mounting
- 🔍 4 Measurement Ranges
- 🔍 12.5mm / 0.5" LCD Digit Height
- 🔍 Compatible with 10kΩ NTC Sensors
- 🔍 5-Wire Connection
- 🔍 Splashproof

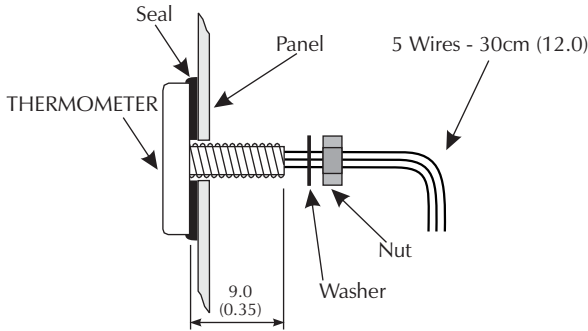

Easy Mounting Thermometer		Stock Number EMT 1900			
Specification	Min.	Typ.	Max.	Unit	
Measurement ranges	°C range (Internal Sensor)	-10		+50	°C
	°F range (Internal Sensor)	+14		+122	°F
	°C range (External Sensor)	-20		+220	°C
	°F range (External Sensor)	-4		+428	°F
Resolution Internal Sensor		0.5 (1)		°C (°F)	
Resolution External Sensor	-20 to +140°C	1 (2)		°C (°F)	
	+140 to +170°C	2 (4)		°C (°F)	
	+170 to +220°C	5 (10)		°C (°F)	
Accuracy*	°C range (Both Sensors)	1		°C (±2 count)	
	°F range (Both Sensors)	2		°F (±4 count)	
Sample rate		3		sample/sec	
Operating temperature range	-10		+50	°C	
Supply voltage**	4		28	V d.c.	
Supply current		1		mA	

\* Using external NTC sensor with 10kΩ @ 25°C and a 25 to 85°C Beta value of 3977, for example: BC Components 2322-640-73103. The module may require recalibration. To ensure maximum accuracy, recalibrate periodically. Calibrate the module at top end of measurement range.  
 \*\* Do not apply more than 28V, as this may damage the meter.

### DIMENSIONS All dimensions in mm (inches)

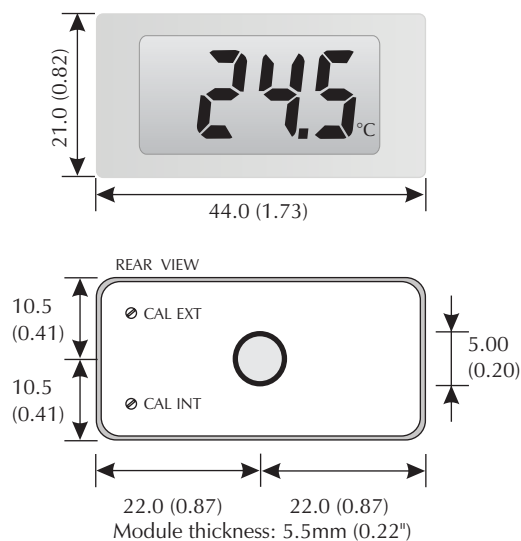

Underrange display



Overrange display

### FITTING THE EMT 1900

Drill a 5.5mm /  $\frac{7}{32}$ " hole in the panel. Fit seal to the rear of the module. Fit the module to the panel by passing its screw threaded stud and the wires through the hole, fitting the washer and tightening the nut provided. Take care not to trap any of the connecting wires. Do not overtighten the nut as this may damage the meter.

- 0. BLACK 0V Negative supply voltage to the module.
- 1. BROWN NTC Connection for external 10kΩ NTC sensor.
- 2. RED V+ Positive supply voltage to the module.
- 3. ORANGE INT/EXT Leave floating to display internal sensor temperature.  
Connect to 0V to display external sensor temperature.
- 4. YELLOW °C/°F Leave floating to select °C measurement range.  
Connect to 0V to select °F measurement range.

**SAFETY**

As the NTC temperature sensor is a passive device, no voltages should be applied to the input terminals of the EMT 1900. The user must ensure that the incorporation of the meter into the user’s equipment conforms to the relevant sections of BS EN 61010 (Safety Requirements for Electrical Equipment for Measuring, Control and Laboratory Use).

**APPLICATIONS**

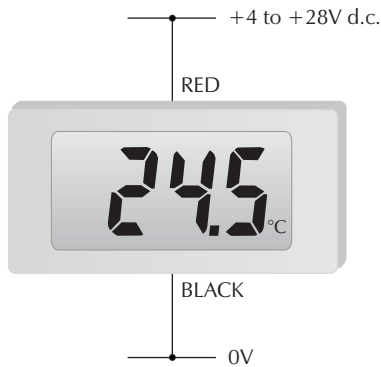

Displaying ambient temperature in °C, using the module's internal temperature sensor.

NTC  
 $R_{25^{\circ}\text{C}} = 10\text{k}\Omega$   
 $\beta_{25-85^{\circ}\text{C}} = 3977 \pm 0.75\%$

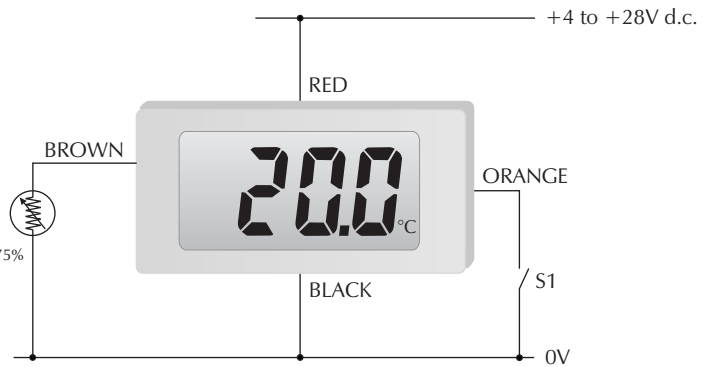

Leave S1 open to display internal sensor temperature in °C. Close S1 to display external Sensor temperature in °C.

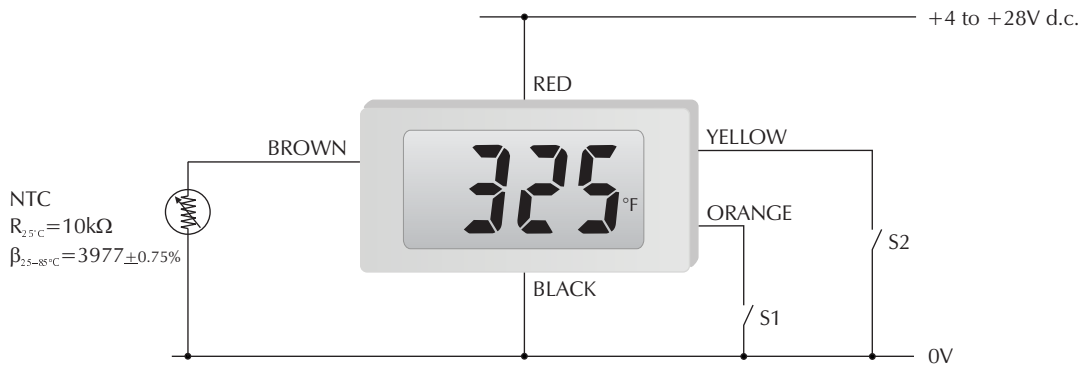

Leave S1 open to display internal sensor temperature.  
 Close S1 to display external Sensor temperature.  
 Leave S2 open to display temperature in °C.  
 Close S2 to display temperature in °F.

Johannesburg Branch  
 **MIMIC COMPONENTS**  
Cape Town Branch  
 Mimic Cape

# Application Notes





# Table of Contents

## Installation and Operation - Section A

1. Basic Principles .....	3
The A to D Converter .....	3
Multiplication & Division .....	4
Specification .....	4
2. Analogue Inputs .....	6
Differential Input .....	6
Differential Reference .....	6
Analogue Common .....	6
Common Mode Rejection Ratio CMRR .....	6
Eliminating Common Mode Errors .....	7
3. Referring Inputs to Supply Ground .....	7
Reducing/Eliminating VCM .....	7
Reducing Ground Loop Errors .....	7
Noise .....	8
4. Interfacing with Linear and Digital Circuitry .....	9
Linear .....	9
Digital Signals .....	10
5. Power Supplies .....	11
Negative Rail Generators .....	11
Operation from Low Volt Supplies .....	11
6. Fitting an External Reference .....	12
7. Parallel Operation .....	12
8. LCD Backlighting .....	12
9. Commissioning the Meter .....	13
Handling .....	13
Circuit Connection .....	13
Bezel Fitting .....	13
Using PCB Links .....	15
10. Troubleshooting .....	15

## Typical Applications - Section B

Measuring Voltage .....	16
Measuring Current .....	16
Measuring Resistance .....	18
Thermometer Circuits .....	19
Using Strain Gauges .....	20
Generating an Offset .....	20
AC-DC Converters .....	21
Autoranging .....	22
Measuring Frequency .....	22



# Installation & Operation - Section A

## 1. Basic Principles

### 1.1 The A to D Converter

The vast majority of Lascar meters operate using the Dual-Slope method of conversion. Put simply, the technique involves charging a capacitor (CINT) from zero at a rate directly proportional to the input voltage and for a fixed time (see fig. 1.2). This is the integrate phase. Then the control connects the reference voltage (note that it is negative) and CINT is discharged at a rate proportional to the reference voltage. This is the reference integrate (or de-integrate) phase, the end of which is determined when the voltage on CINT is zero. The time taken for CINT to discharge is directly proportional to VIN and the number of clock pulses counted in this period gives the digital result.

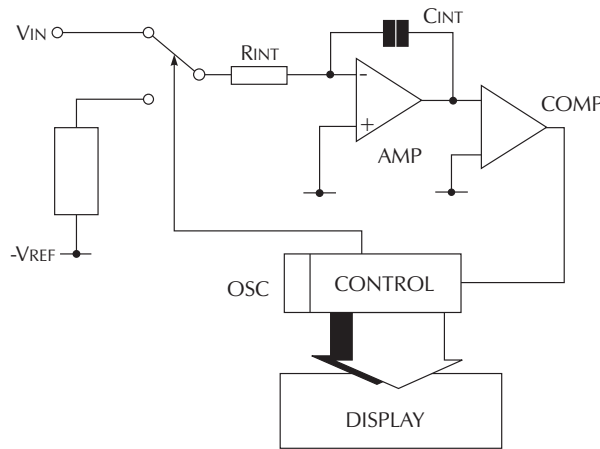

Fig. 1.1 INTEGRATOR BLOCK DIAGRAM

By using electronic switching and a capacitor to store the reference (CREF), the reference voltage is always applied with the opposite polarity to VIN. Fig. 1.2. shows the result for a negative input.

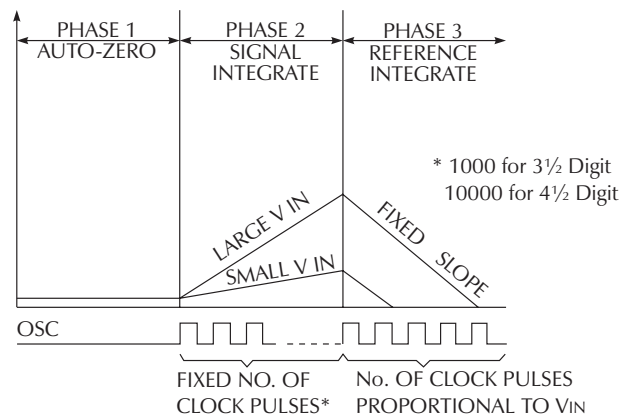

FIG. 1.2 INTEGRATOR CONVERSION CYCLE

In the Auto Zero phase, errors in the analogue circuitry (op-amp input offset voltages for example) are nulled by grounding the input, closing a feedback loop and storing an error offset voltage on the auto zero capacitor (CAZ)\*.

\*Not Illustrated



# Installation & Operation - Section A

## 1.2 Multiplication & Division

Most Lascar voltmeters have either 3½ or 4½ digit resolution. That is a maximum reading of either ±1999 or ±19999. This will usually correspond to a full scale reading of ±199.9mV (VREF=100mV) or ±1.9999V (VREF=1.00V).

The relationship is given by:-

$$\text{READING} = 1000 \times \frac{\text{VIN}}{\text{VREF}} \quad (3\frac{1}{2}) \quad (1.1)$$

$$\text{OR} = 10000 \times \frac{\text{VIN}}{\text{VREF}} \quad (4\frac{1}{2}) \quad (1.2)$$

The DPM 160 achieves either 200mV or 2V full scale reading (for a 1V reference) by digitally selecting either 10000 or 1000 clock pulses during the signal integrate period. Thus for a DPM 160 in 200mV scale:-

$$\text{READING} = 10000 \times \frac{\text{VIN}}{\text{VREF}} \quad (1.3)$$

The DPM 160 uses a more complex system of successive integration and de-integration to achieve the required range of 4½ digits (on the 200mV range the resolution is 10mV). With VREF fixed and VIN varied, the system will multiply (see equations 1.1 - 1.3). However, if VIN is fixed and VREF is the input, the system will divide. This can be used with effect in applications measuring period from the output of a F-V converter for example, or any other requiring a reciprocal function - e.g. velocity

## 1.3 Specification

### 3½ DIGIT INSTRUMENT

USING THE ICL 7136 / MAX 131	DPM 125 DPM 942-BL	DPM 2000(S) DPM 400	DPM 500(S) DPM 600(S) DPM 700(S)	DPM 702S DPM 942 DPM 950(S)
USING THE MAX 136	DPM 116			
USING THE MAX 138	DPM 125-BL DPM 1AS-BL DPM 2AS-BL DPM 3AS-BL EMV 1125	DPM 742-BL DPM 750S-BL DPM 750S-EB-W EMV 1025S	DPM 342 SP 200 OEM 1B EM32 1B	SP 400 SP 400-BLUE SP 400-EB-W
USING THE MAX 140	DOM 340 DPM 959B OEM 1B-LED EM32 1B-LED	SP 100 SP 8-100 SP 300-BLUE DPM 40	SP 300	

TABLE 1 - MAX 136, 140, 138 SPECIFICATIONS

PARAMETERS	CONDITIONS	MIN.	TYP.	MAX.	UNIT
Zero input reading	Vin = 0V Full Scale = 200mV	-0	+0	+0	Reading
Fluorimetric reading	Vin = Vref Vref = 100mV	998	999/1000	1000	Reading
Rollover error (Difference between equal, positive and negative reading near full scale.)	-Vin = + Vin = 200mV	-1	+0.2	+1	counts
Linearity (Maximum deviation from best straight line fit)	Full Scale = 200mV or Full Scale = 2.00V	-1	+0.02	+1	counts
Common Mode Rejection Ratio (CMRR)	Vcm = +1V, Vin = 0V Full Scale = 200.0mV		1		µV/V
Leakage current at input	Vin = 0V		1	10	pA
Zero reading drift	Vin = 0V, 0°C< Ta< +70°C		0.2	1	µV/°C
Scale factor temperature coefficient	Vin = 199.0mV, 0°C< Ta< 70°C (Ext Ref 0ppm/0°C)		1	5	ppm/°C
Supply current (Does not include COMMON or REF current)	Vin = 0V		70	100	µA(MAX 136)
			200	500	µA(MAX 138)
Analogue COMMON Voltage (with respect to positive supply)	250k between Common and Positive supply (25k MAX 136)	2.6 2.95	2.8 3.05	3.2 3.15	V (MAX 136) (MAX 138)
Temperature coefficient of Analogue COMMON (with respect to positive supply)	250k between Common and Positive supply (25k MAX 136)		80 20		ppm/°C (MAX 136) (MAX138)
Pk - Pk Segment Drive (MAX 136/MAX 138)	V+ to V- = 9V	4	5	6	V
Pk - Pk Backplane Drive (MAX 136/MAX 138)	V+ to V- = 9V	4	5	6	V
<b>MAX 140 ONLY</b>					
Segment Sinking Current	Except AB4 AB4 only	1.5 3	2.5 5		mA



# Installation & Operation - Section A

## 1.3.2 4 ½ Digit Instruments DPM 160 uses the ICL 7129A

TABLE 2 - ICL 7129 SPECIFICATION.

PARAMETERS	CONDITIONS	MIN.	TYP	MAX.	UNITS
Zero input reading	V <sub>in</sub> = 0V Full Scale = 200mV	-0	+0	+0	Reading
Zero reading drift	V <sub>in</sub> = 0V , 0°C< Ta< + 70°C		+ 0.5V		µV/°C
Range change accuracy	V <sub>in</sub> = 0.1V on Low Range + V <sub>in</sub> = 1.0V on High Range	0.9999	1	1.0001	Ratio
Ratiometric reading	V <sub>in</sub> = V <sub>ref</sub> , V <sub>ref</sub> = 100mV Range = 2V	9998	9999	10000	Reading
Rollover error	-V <sub>in</sub> = + V <sub>in</sub> = 199mV		0.5	1	Counts
Linearity error	Full Scale = 200mV		0.5		Counts
Common Mode Rejection Ratio	V <sub>cm</sub> = + 1V, V <sub>in</sub> = 0V Full Scale = 200mV		110		dB
Common Mode Voltage Range	V <sub>in</sub> = 0V Full Scale = 200mV	V- + 1.5		V+ - 0.5	V
Noise (p-p value not exceeded 95% of time)	V <sub>in</sub> = 0V Full Scale = 200mV		7		µV
Input leakage current	V <sub>in</sub> = 0V , P <sub>in</sub> 32,33		1	10	pA
Scale factor temperature coefficient	V <sub>in</sub> = 199.0mV, 0°C< Ta< + 70°C		2	5	ppm/°C
COMMON voltage	V+ to pin 28	2.8	3.2	3.5	V
COMMON sink voltage	COM raised by 0.1V		0.6		mA
COMMON source voltage	COM lowered by 0.1V		12		µA
DGND voltage	V+ to pin 36, V+ to V- = 9V	4.5	5.3	5.8	V
DGND sink current	DGND raised by 0.5V		1.2		mA
Supply voltage range	V+ to V-	6	9	14	V
Supply current (excluding COMMON current)	V+ to V- = 9V		1	1.4	mA
Clock frequency			120	360	kHz
Display multiplex rate	f <sub>CLK</sub> = 120kHz		100		Hz
VDISP resistance	VDISP to V+		50		k
Low battery threshold	V+ to V-	6.3	7.2	7.7	V
Continuity threshold	V <sub>out</sub> P <sub>in</sub> 27 = HI	100	200		mV
	V <sub>out</sub> P <sub>in</sub> 27 = LO		200	400	
Pull down current	P <sub>ins</sub> 37 , 38, 39		2	10	µA
"Weak Output" current	P <sub>ins</sub> 20, 21 Snk/Source		3/3		µA
Snk source	P <sub>in</sub> 27 Snk/Source		3/9		µA
Pin22	Source current			40	µA
	Sink current			3	µA



# Installation & Operation - Section A

## 2. Analogue Inputs

### 2.1 Differential Input

The analogue inputs for VIN (IN HI and IN LO) respond to the voltage between them and not their voltage with respect to any other signal. Because of this, the inputs are said to be "differential". This makes them very versatile when interfacing to various circuits because offsets can be eliminated. The extent to which the inputs can be offset and still remain truly differential is known as the common mode range. The limits to this range being 1.5V\*\* below V+ and 1.5V\*\* above V-. It is recommended not to operate either input close to the power supply rails, because of potential non-linearity problems with the integrator section.

\*\* This range below V+ to above V- varies depending on the IC series fitted to the DPM. Full details of this can be found in the IC manufacturers' original data.

### 2.2 Differential Reference

The reference voltage VREF (REF HI and REF LO) may be anywhere within the power supply voltage range of the converter. However, if there is a large voltage between the reference input and COM there is a risk that stray capacitance in the analogue switching circuitry (see 1.1) will cause a noticeable roll-over error (see 2.5). Roll-over error is the difference in reading between identical positive and negative inputs.

1. Note some units have IN LO and/ or REF LO linked to COM. MAX 136 based meters have REF LO permanently connected to COM.
2. All LED and S version LCD instruments generate their own negative supply that is below the 0V power supply rail. N.B. Beware of conflicting terminology here. Traditionally non 'S' LCD meters have power supply connections V+ and V- and were designed to operate from 9V nominal. In contrast, 'S' type LCD meters often use V+ and V- as power supply connections, BUT operate from 5V nominal (not 9V). Many have a '-5V' output which is the on-board generated negative rail. For newer meters such as the SP Series, power supply and connectors are typically referred to as V+ and GND for 5V operation (-5V is available on V-) or V+ and V- for 9V operation.

### 2.3 Analogue Common

This pin is included primarily to set the common mode voltage (VCM) for battery operation (LCD), or for any system where the input signals are floating with respect to the power supply. The COM pin sets a voltage that is approximately 2.8 volts more negative than the positive supply. This is selected to give a minimum end-of-life battery voltage of about 6V. However, COM can be used as a reference voltage. When the total supply voltage is large enough to cause the zener to regulate (>7V), the Common voltage will have a low voltage coefficient (.001%), low output impedance (<15W), and a temperature coefficient typically less than 80ppm/°C.

Within the IC, COM is tied to an N-channel FET that can sink 300mA or more to hold the pin 2.8 volts below the positive supply (when a load is trying to pull COM positive). Sinking excessive current into COM can seriously damage the unit. However, there is only 1mA of source current, so COM may easily be tied to a more negative voltage, thus overriding the internal reference.

### 2.4 Common Mode Rejection Ratio CMRR

This gives a measure of the quality of the differential inputs and is expressed in dB. It means that if there is no input (VIN = 0) and the CMRR is say (-)100dB, when you impose a voltage of 1.0V between IN LO and COM.

(See fig 2.1) the resulting offset should not exceed:-  
 $1.0 \times 10^{\frac{(-100)}{20}} \text{ V} = 10\mu\text{V}$   
 or 10μV per volt of common mode voltage.

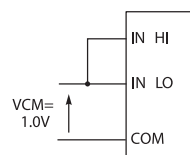

Fig 2.1 Determining CMRR



# Installation & Operation - Section A

Thus for a 4½ digit display the offset will only be a fraction of one count (with 200mV FSR the least significant digit records 10's of mV) Earlier designs of panel meter circuits used COM as the ground reference during integration. These had a lower CMRR of typically 86dB and ideally IN LO should be connected to COM to eliminate offsets. Except where COM is being used as a ground reference (see 2.3), IN LO need not be tied to COM.

## 2.5 Eliminating Common Mode Errors

The following sections give advice on suitable grounding arrangements. Because of the high Common mode performance of modern A/D converters, it is not essential to have 0V VCM. It is, however, essential that you avoid going too close to or beyond the power supplies.

## 3. Referring Inputs to Supply Ground

In many applications the meter will need to be powered from the same supply as the circuit under test. There are three pitfalls to be avoided here.

1. Applying excessive common mode voltage ( $V^{CM}$ ) (see Section 2).
2. Ground loop errors.
3. Noise.

### 3.1 Reducing/Eliminating VCM

Referring to section 2.1, it will be seen that the negative power supply should be at least 1.5V below the analogue inputs.

We must, therefore, provide a negative supply. All LED instruments provide their own. All S-type LCD meters do likewise. If a suitable negative supply is not available, one must be provided or a different meter chosen for the application.

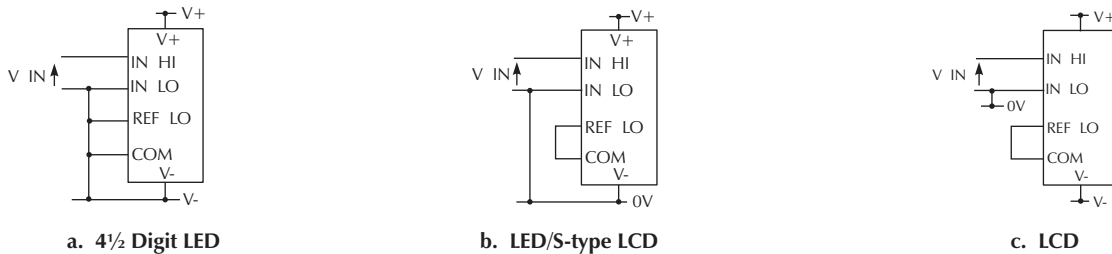

Fig 3.1 Ideal circuit connections

### 3.2 Reducing Ground Loop Errors

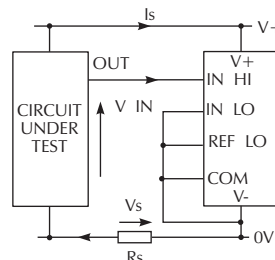

Fig 3.2 Errors due to supply impedances

If we redraw fig 3.1 we will see that small impedances ( $R_s$ ) in power supply lines will cause a volt drop ( $V_s$ ) which will be subtracted from the reading, causing an offset. Furthermore, with LED meters not only do they have a much higher current consumption (causing significant offsets), but each reading results in a different current consumption. If there is a change in current consumption there is a change in the reading which causes a change in current consumption, etc. A good example would be a DPM 40 reading say 1001. A drop of one count gives 1000, a difference of 4 segments in the least significant digit. Each segment consumes 8mA. Thus the total change in current is  $4 \times 8 = 32\text{mA}$ . Under these conditions it only needs  $R_s$  to be  $6\text{m}\Omega$  to cause a 2 count offset.



# Installation & Operation - Section A

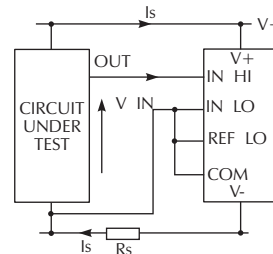

Fig 3.3 Eliminating the effect of supply impedances

Using the application in Fig. 3.3 you will reduce the effects of any supply borne interference.

## 3.3 Noise

Electrical noise can be generated from stray electric, magnetic and electromagnetic fields as well as from supply and signal borne interference. Although meters have very good line regulation and CMRR, they will be affected by excessive amounts of noise. Remember that meter signals are referred to V+ and any suppression capacitors should be fitted between COM and V+. Each case of noise problems will have its own solution. Below is a list (in order of importance) of possible remedies.

### 3.3.1. Ground Noise

Check that there are no signal errors due to ground loop impedances. See Section 3.2.

### 3.3.2. Power Supply

Supplies that are likely to generate noise, such as those with noisy loads or switching converters, need to be suppressed. Decouple the meter supply at the meter and if necessary place a choke in the positive supply. Remember that electrolytic capacitors can be inductive and it is better to decouple with solid tantalum capacitors.

### 3.3.3. Signals

All meters have input filters which reduce noise, however, where the signal leads to the meter are long, use twisted pair wires and place any attenuator networks at or on the meter. In extreme cases, use screened leads but be careful not to connect the screen to any noisy signal or power line. Only screen the lead to COM at the meter. Ferrite beads can be very effective in reducing noise in signal lines.

### 3.3.4. Stray Fields

If stray electrical or magnetic fields are suspected of causing noise, physical screening of the meter may be necessary. Other measures include placing the meter away from cables that are likely to have large and noisy currents in them. Another source of magnetic interference will be any transformer, especially one operating at high frequency.



# Installation & Operation - Section A

## 4. Interface With Linear and Digital Circuitry

### 4.1 Linear

As mentioned in Sections 2 and 3, the most important aspect is to ensure that ground voltage levels do not cause problems. For the sake of simplicity, we shall assume the linear circuit to be an op-amp. A number of linear systems can exist:

Circuit operating from  $\pm$  supplies, e.g. 5 - 0 - 5V (LCD). Circuit operating from a single supply but needing a ground level to be generated in between,

e.g. battery operated equipment (LCD). Circuit operating from a single supply with its output referenced to the negative (GND) supply (LED, S-type LCD).

#### 4.1.1 Split Supply Operation

If the signal to be measured is referred to ground, then IN LO will be connected to ground and IN HI to the signal. However, ensure that IN LO is connected as close as possible to the ground connection point of the signal.

Advice on referring inputs to ground lines is given in Section 3. Be careful not to exceed the maximum supply voltage; the maximum supply voltage quoted in data sheets is the maximum voltage between V+ and V-. If the maximum supply voltage is 15V, the maximum split supply is  $\pm 7.5V$ .

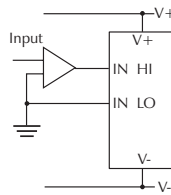

Fig 4.1 Split supply operation

#### 4.1.2. Generating a Ground Level in Battery Powered Equipment

If the battery is formed with separate cells it is as well to have a centre-tap in the battery for the ground (0V). However, if you are using a packaged battery such as the PP3, then other means are needed. The solution is to use either the COM or TEST (DGND) pins on the meter as the ground. The choice depends on the circuit that must operate with the meter but there are a few considerations:

- i. Using COM eliminates all common-mode voltages and because it is approximately 3V below V+, the ground will be well separated from either supply rail even if the battery voltage drops down to 6V.
- ii. TEST (DGND) may be a better choice if running off higher supplies such as 12V vehicle batteries.
- iii. COM can sink but not source current. Any load on COM must not pull COM down towards the negative supply.
- iv. TEST (DGND) can sink or source up to 1mA and is the ground for the internal meter logic.
- v. If a load exceeding the conditions laid out in iii. and iv. above is likely, then the ground needs to be buffered.

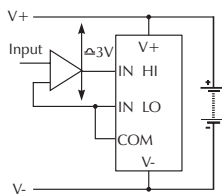

Fig. 4.2.a Using COM to generate signal ground

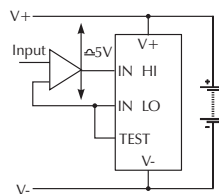

Fig. 4.2.b Using TEST to generate signal ground

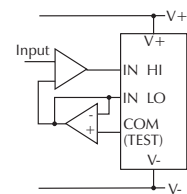

Fig. 4.2.c Buffering the ground.





# Installation & Operation - Section A

## 5. Power Supplies

The best power supplies for meters are either batteries or linear regulated mains supplies. Ideally each meter should have its own supply and that supply should be isolated. Where one supply is operating more than one meter or the meter is powered from the same supply as the circuit under test, great care is needed to ensure safe and trouble free operation (see sections 6).

All mains powered meters have internal isolated supplies. Lascar manufacture a number of small PCB based supplies which are suitable for powering meters (PSU 201, PSU 203, PSU 206 PSU 30105, PSU 30205 and PSU 303).

When using mains power supplies and generally where the circuit being measured has several supply voltages, take care that at power-on and power-off no harmful conditions exist that may damage the meter. The typical case is when, due to transients, the inputs to the meter are taken beyond the supply rails to the unit and excessive current flows in the meter signal lines. Use current limiting resistors and/or clamp the inputs to the power supply lines.

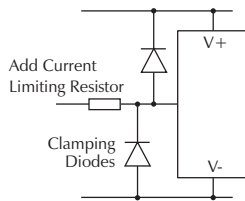

Fig 5.1 Signal input protection

### 5.1. Negative Rail Generators

Normally we recommend that if a negative rail is needed for a meter, a meter is used with an inbuilt negative supply (LED and S-type LCD meters). If you choose one without a negative supply, then use the circuit shown in Fig. 5.2.

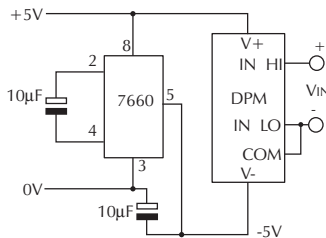
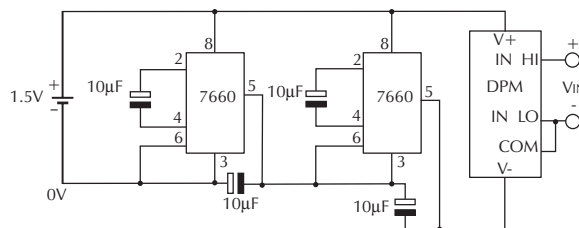

Fig. 5.2 Negative rail generator

### 5.2. Operation From Low Volt Supplies

Fig. 5.3. gives a suggestion for operating from a single 1.5V cell.





# Installation & Operation - Section A

## 6. Fitting an External Reference

Sometimes a different calibration range may be needed or a more precise reference fitted, for example, where the meter does not have a bandgap reference.

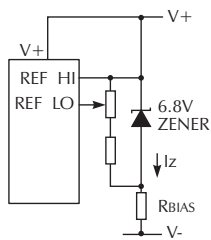

Fig. 6.a Zener Diode Reference

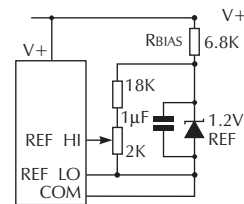

Fig. 6.b Using a Bandgap Reference.

## 7. Parallel Operation

Some applications will have more than one meter measuring in a circuit. It is very easy in these circumstances to have erroneous readings or worse. Fig. 7.1. gives an example of how, even with an isolated supply, it is possible to destroy at least one meter. With shunts in each of the  $\pm 24V$  supplies, there will be 48V between the meter IN LO inputs. Fig. 7.2. shows a better arrangement. The general rule is don't use the same supply if you cannot use the same signal ground.

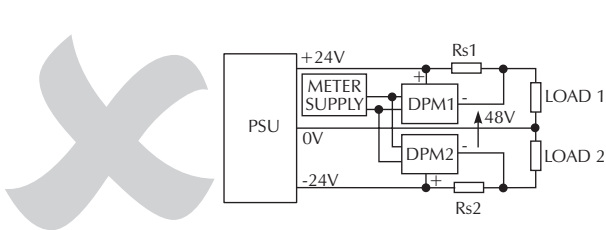

Fig 7.1 How not to use common supplies

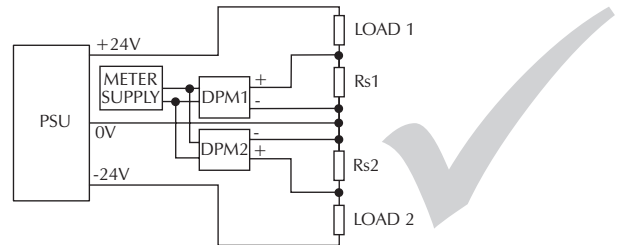

Fig. 7.2 How to use common supplies

Ensure that when meters with internal references are parallel and COM is used as the ground, (e.g. in battery powered equipment) the references do not 'fight' each other; the meter with the highest COM - V+ voltage will pull all the other COM voltages lower and only one meter will be accurate. In these cases, use one meter to define the ground and leave the others with their COM pins unconnected. Check that programming links do not connect COM to IN LO inside the meter.

## 8. LCD Backlighting

Several Lascar LCD displays feature LED backlighting you should review the operating mode for the backlight on the data sheet for each display.



# Installation & Operation - Section A

## 9. Commissioning the Meter

### 9.1 Handling

Lascar meters do not normally need special handling precautions but they do contain CMOS circuitry and static should be avoided. When soldering, use irons with earthed tips and avoid applying excessive heat to the meter's PCB. The recommended tip diameter should be between 1 and 2mm and flat, not pointed. Large tips can transfer too much heat to the PCB and thin ones physically damage it whilst being inefficient at bridging solder across programming links. If it is necessary to transport meters, e.g. via carrier, post, etc. then ensure that the unit is well packed. This is especially important in the case of LCD panel meters. Keep bezel materials away from the glass and do not use such packaging as 'padded' bags. Firm cardboard boxes should be used. Padded bags may protect against impact but not against crushing.

### 9.2 Circuit Connection

It is recommended that all connections to the meter be made with a socket. Do not solder to meters which have IC type pins on them. In some cases the meter is supplied with sockets.

Always check that the power supply is correct and that the signals will not destroy the meter before connecting the unit. Take care that power-on transients will not apply destructive voltages to the meter.

### 9.3 Bezel Fitting

Below are illustrations of the various techniques used to mount meters in panel cut-outs.

1. Turn lugs to fit thick or thin panels.
2. Screw lugs loosely into the bezel.
3. Fit bezel to the panel and turn lugs to grip the rear of the panel.
4. Fit the meter.

In some cases it may be easier to fit the meter to the bezel before fitting the assembly to the panel.

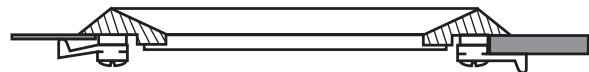

**Fig. 9.1** Moulded window type fitting

Locate the meter by passing it through the front of the panel cut-out, gently pushing until the rear of the bezel is flush with the panel (DO NOT PUSH ON THE LCD). The snap-in lugs will now automatically hold the meter firmly in position.

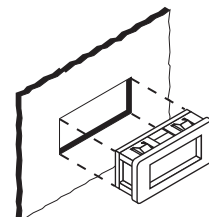



# Installation & Operation - Section A

Fit the bezel to the front of the panel and then locate the meter into the bezel from behind. Alternatively the meter and bezel may be assembled before fitting into the front of the panel but care must be taken not to use excessive force. Finally fit the window into the front of the bezel.

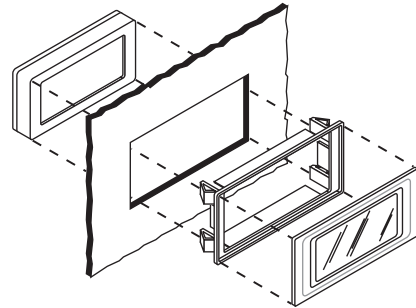

Fig. 9.4 100 Series modules

Fit the bezel to the front of the panel, then locate the meter to the bezel from behind the panel. Using the screws provided, secure the two plastic spring clips to the rear of the meter. The meter is designed to fit directly onto OKW Type M, P and Veronex size 3 enclosures.

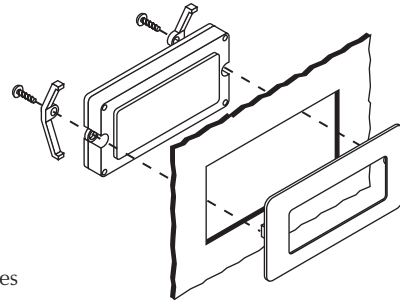

Fig. 9.5 700 Series modules

Locate the four posts on the rear of the bezel into the holes in the front of the module. Place the module into the panel cut-out until the bezel is flush with the panel. align the mounting clips at each side of the module and secure in place with screws provided.

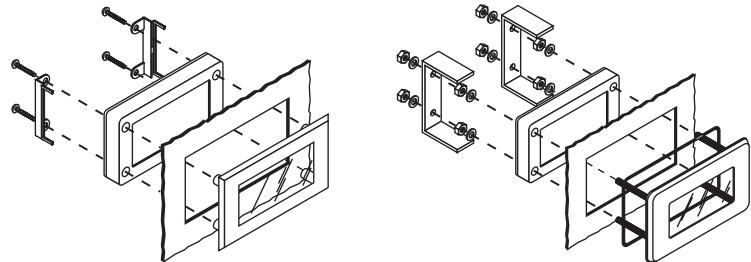

Fig. 9.6 900 Series modules

**Note:** an IP67 / NEMA 4X bezel (BEZ 900-IP) is available - shown right.

Locate the meter by passing it through the front panel cut-out, gently pushing until the rear of the bezel is flush with the panel. The snap-in lugs will now automatically hold the meter firmly in position.

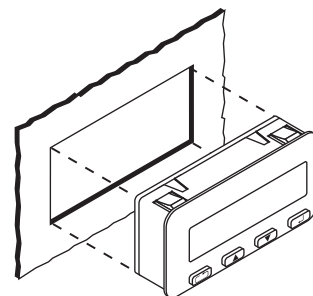

Fig. 9.7 Din Cased Series modules



# Installation & Operation - Section A

Slide the seal over the rear of the meter and fit round the meter rim. Locate the meter by passing it through the front of the panel cut-out and push until the rear of the bezel is flush with the panel. Slide the fixing clip over the rear of the module and press firmly into place.

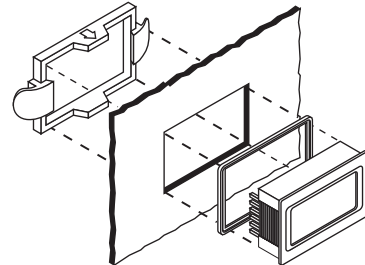

Fig. 9.9 SP Series modules

Fit the module to the bezel and slide the assembly through the panel. Fit the retaining clip over the bezel pillars and fix using push-on fasteners.

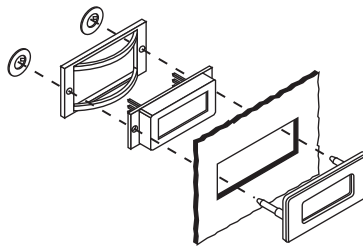

Fig. 9.10 V Series modules

## 9.4 Using PCB Links

Many Lascar meters have programming pads to make circuit configuration quick and easy. Some pads are almost always closed by the customer and in these cases the pad will have a small PCB link across it. If you need to cut the link, use a sharp scalpel and be careful not to damage adjacent tracks. The basic technique is to dig the link out rather than slice through it (see Figs. 9.5 and 9.6).

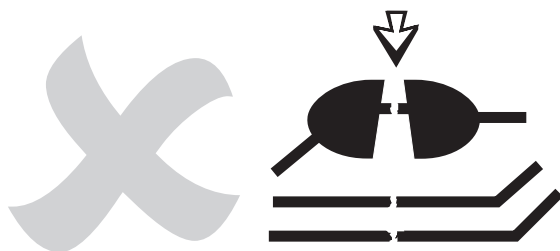

Fig. 9.5 How not to cut PCB links

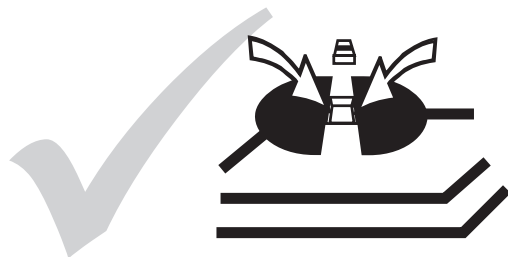

Fig. 9.6 How to cut PCB links

Take care not to apply excessive force to fine blades which can break. Wear eye protection.

## 10. Troubleshooting

The majority of difficulties stem from application problems. If a meter is suspected of malfunctioning, remove it from the circuit and connect it up on its own in the 'Floating Supply Mode' (see meter data sheet - back page) and apply an isolated signal. If the meter works satisfactorily, check the circuit, otherwise contact a Lascar Applications Engineer. The most common problem occurs when the meter is subjected to signals outside its common mode range or where there is a ground supply error (see sections 2 and 3).



# Typical Applications - Section B

## 1. Measuring Voltage

Because all meters measure d.c. voltage this is the simplest parameter to measure. The most common interface circuit is a voltage attenuator. Fig. 1. gives an example of a multi-range attenuator.

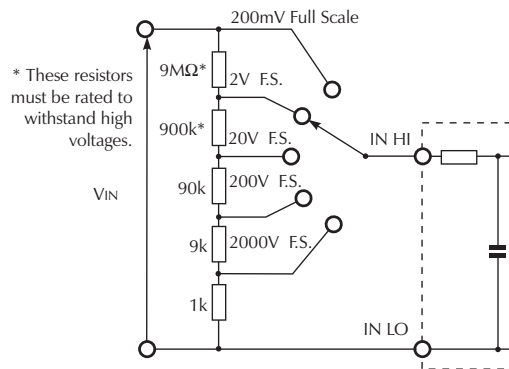

Fig. 1 Multi-range Voltmeter

## 2. Measuring Current

Although measuring current simply means measuring the voltage across a low value resistor which has been placed in series with the current, there are some potential pitfalls (see Chapter 1, section 6). The thing to remember is to ensure that the signal to the meter is within its common mode range.

The commonest mistake is to place the shunt in the positive supply with the meter referred to ground. If it is possible, place the shunt in the ground line, but be careful not to superimpose the meter supply current in the reading. Always use the 'Four Terminal' technique to avoid errors due to terminal resistance, etc. If it is essential to have the shunt in the positive supply, use an isolated meter supply or the circuit shown in Fig. 2.a.

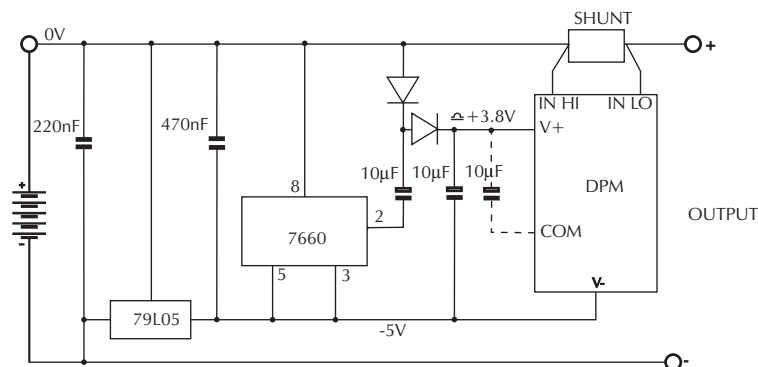
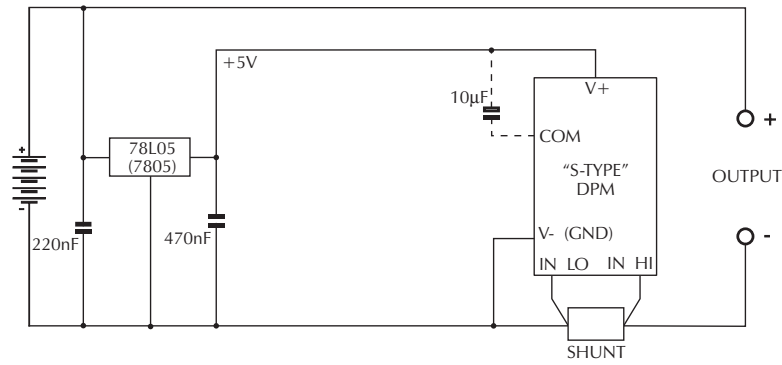

Fig. 2.a Positive Supply Shunt (LCD only)



# Typical Applications - Section B

Always ensure IN LO is not connected to COM. Fig. 2.b. gives the preferred application for LED and S-type LCD meters.



**Fig. 2.b** LED and S-type LCD Current Monitoring

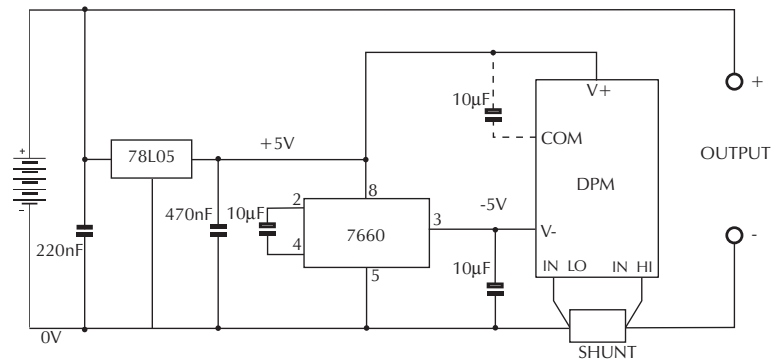

**Fig. 2.c** Normal LCD Current Monitoring

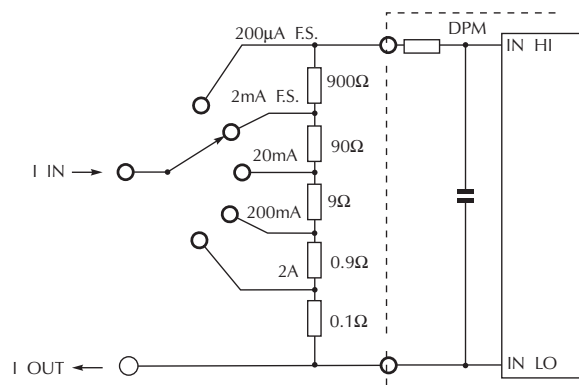

**Fig. 2.d** Multi-range Current Measurement



# Typical Applications - Section B

## 3. Measuring Resistance

There are two basic methods of measuring the value of a resistor. The first is to pass a known current through it and measure the volt drop. While this method is accurate, it usually means constructing a constant current generator with a voltage reference and some active elements.

The second is easier, requires few external components and, provided the reference resistor used is accurate, needs no calibration. Known as the ratiometric method, it uses a known resistor to generate a reference voltage and the unknown resistor to supply the input.

Referring to Chapter 1, section 1.2:-

$$\text{READING} = 1000 \times \frac{V_{IN}}{V_{REF}} \quad 3\frac{1}{2} \quad (1.1)$$

Refer to Fig 3.1 and rewriting equation 1.1:-

$$\text{READING} = 1000 \times \frac{V_u}{V_s} \quad (3.1)$$

Now  $V_s = I_L \cdot R_s$  and  $V_u = I_L \cdot R_u$ . Substituting in 3.1:-

$$\text{READING} = 1000 \times \frac{R_u \cdot I_L}{R_s \cdot I_L} \quad (3.2)$$

Thus:-

$$\text{READING} = 1000 \times \frac{R_u}{R_s} \quad (3.3)$$

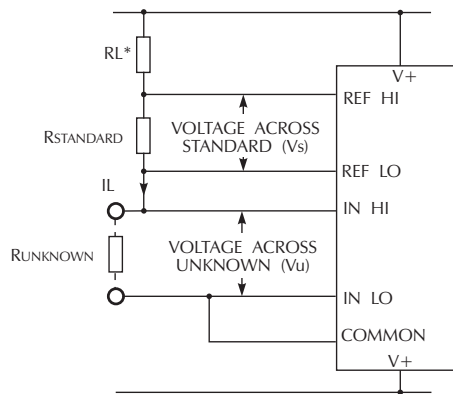

**Fig. 3.1** Ratiometric Resistance Measurement

\*RL should be chosen to set the value of Vs in the range 50 - 200mV. Tip, if RSTANDARD is to be switched (multi-range or multimeter type application), then in order to avoid the need to change RL as each range is selected, RL can be replaced by 3-4 (forward biased) diodes in series. Only use meters that can have their own reference circuits disconnected and which have access to the Reference inputs.

Below follows a table as a guide to suitable DPMs for this method. Note, whilst not shown in the table, parts where REF LO is hardwired to COMMON may still be used by re-configuring the RSTANDARD and RUNKNOWN divider sequence. For example DPM 116, DPM 443, DPM 443M, DPM 45, DPM 850S, EMV 1125, SP 100 and SP200. Alternatively the DMM 939 is available where resistors etc are already provided on-board.



# Typical Applications - Section B

## 4. Thermocouple Circuits

The simplest way is to use a Lascar panel mounted temperature meter (DTM 995 or EMT 1900). However it is also possible to use a DPM with front end circuitry.

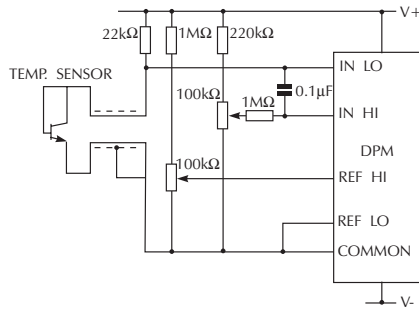

Fig. 4.1 Using a Transistor as the Sensor

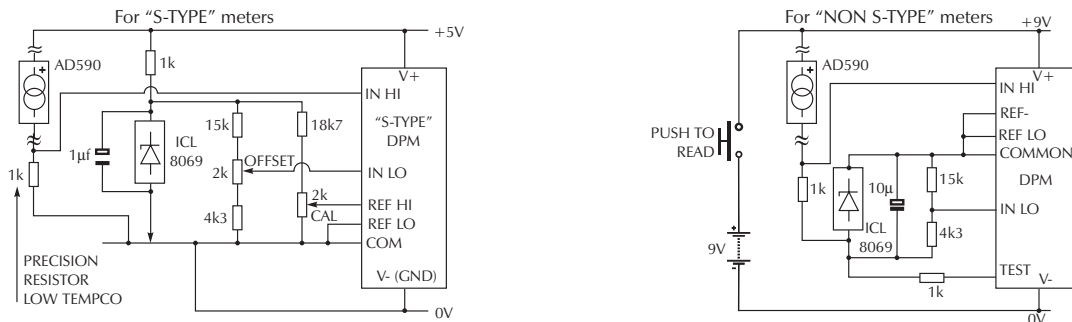
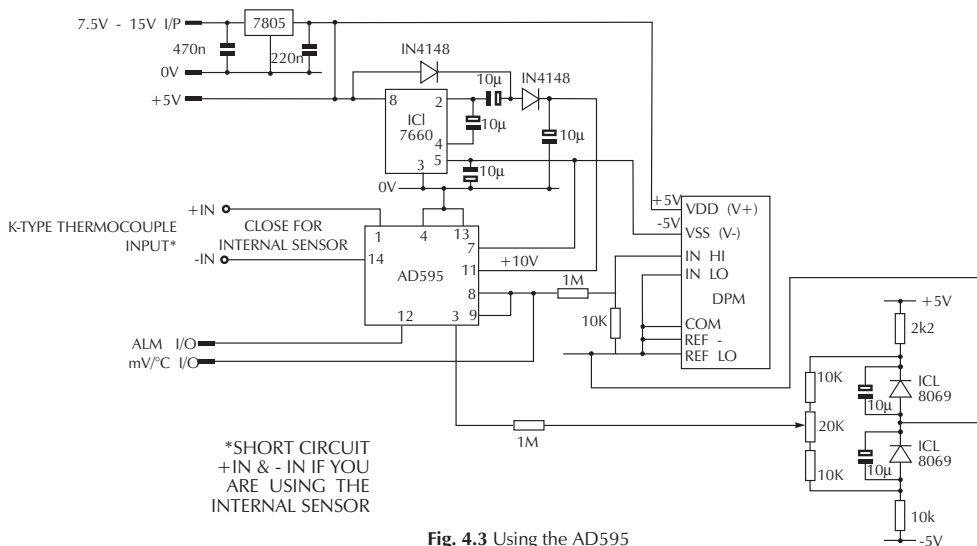

Fig. 4.2 Thermometer using the AD590



\*SHORT CIRCUIT +IN & - IN IF YOU ARE USING THE INTERNAL SENSOR

Fig. 4.3 Using the AD595



## Typical Applications - Section B

### 5. Using Strain Gauges

The strain gauge circuit is a variation of the resistance circuit as seen in section 3 above. It gives a reading of bridge imbalance as a ratio of the applied voltage and is thus independent of supply voltage. As with the resistance circuit, ensure you choose a meter with separate input and reference connections and which can have the meter reference disconnected. Arrange the ratio of R1 to R2 to give approximately 100mV across R2.

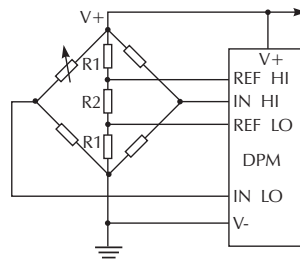

Fig. 5 Strain Gauge Application

### 6. Generating an Offset

Some applications need the meter to have an offset (eg. tare). The basic method is to apply the signal between IN HI and COM and apply the offset between COM and IN LO.

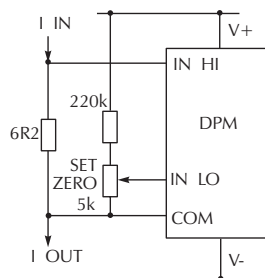

Fig. 6 4-20mA Reading (200mV FSR meter)



# Typical Applications - Section B

## 7. AC-DC Converters

The simplest way is to use a Lascar panel mounted AC meter (DPM 970). However it is also possible to use a DPM with front end circuitry. Two basic techniques for AC-DC conversion exist. The simplest is the 'Precision Rectifier' whose output is the average of the AC input. Provided that the waveform of the input is constant, the meter can be calibrated to read RMS values. The second is the true RMS converter. This can give the true RMS value of the input and is recommended for such applications as monitoring the current in SCR controlled loads.

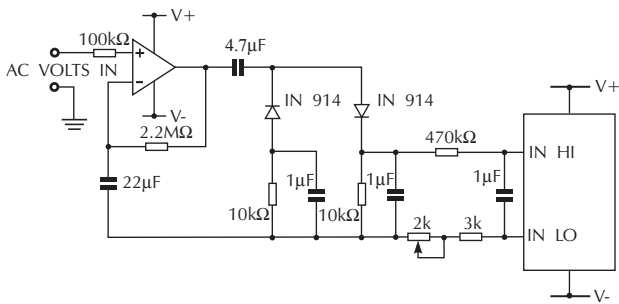

Fig. 7.a Averaging Converter Using a Single Op-amp

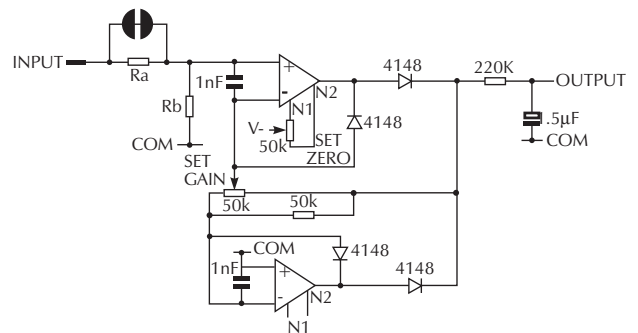

Fig. 7.b High Performance Averaging AC-DC Converter

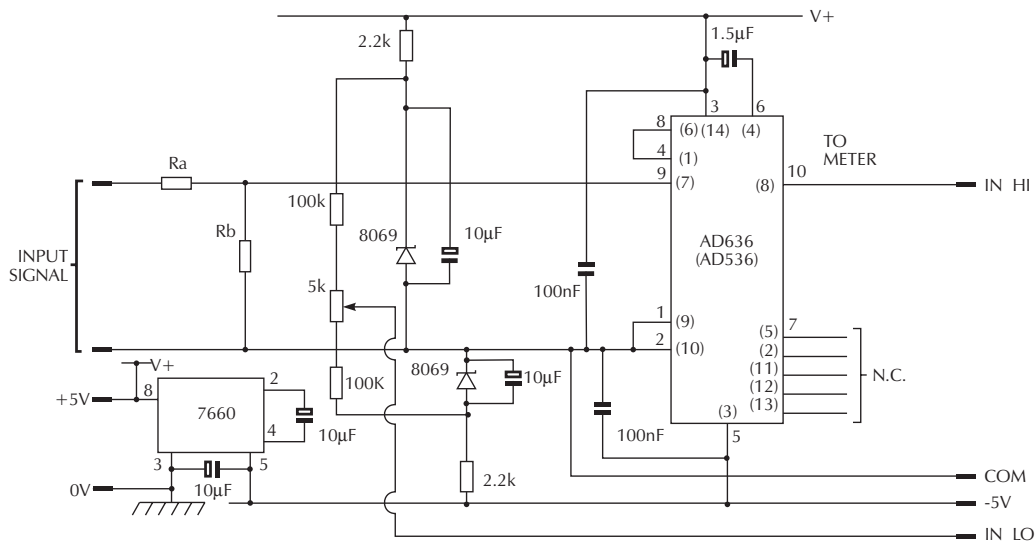

Fig. 7.c Using the AD636 (AD 536)



# Typical Applications - Section B

## 8. Autoranging

If you are planning to design for applications where the meter will automatically change range, you will need to know when the meter is over or under range.

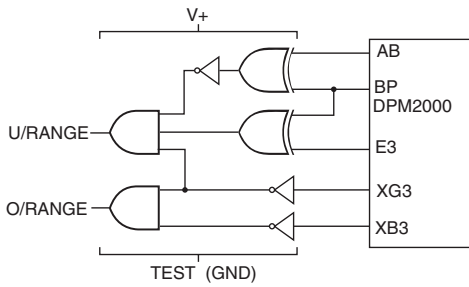

**Fig. 8.a** Generating Overrange and Underrange Signals from LCD Meters

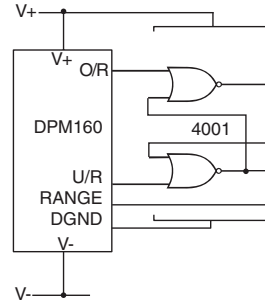

**Fig. 8.b** Simple Two Range 4½ Digit LCD Meter

## 9. Measuring Frequency

Measuring frequency is done by a frequency to voltage converter. One advantage of the F/V converter over the more conventional digital frequency meter is that it has a faster response to low frequencies.

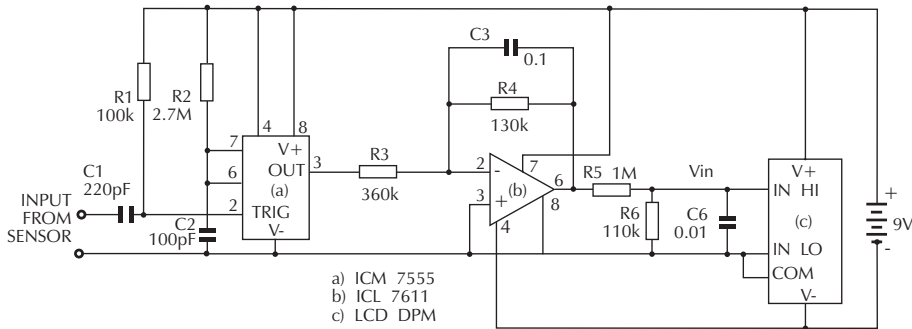

**Fig. 9** Measuring Frequency