

Johannesburg Branch
MIMIC COMPONENTS
Cape Town Branch
Mimic Cape



FEATURE

- Earth Leakage Current Monitoring In 1Ø - 2W, 3Ø-3W And 3Ø-4W System
- Test Mode Available.
- Auto/Manual Tripping Reset Facility.
- LED Indication (25% , 50% , 75%, Trip , Alarm, Delay Time).
- Test/Trip Reset Via Front Key / Remote

TECNICAL SPECIFICATION

INPUT SPECIFICATION :

Input Current	0.03 A To 30.0 Amp AC
Display Currant Range	0.03 To 30.0 Amp AC
Resolution	If Current in Amp = 0.01A If Current in 10 A Above = 0.1 A

DISPLAY AND KEYS:

Display	Upper: 3 digit, 7 segment, 0.4" (White) Lower: 3 digit, 7 segment, 0.28" (Green)
Keys	SET, INC, DEC / RST

DIMENSION :

Size (mm)	90(H) X 35(W) X 61.5(D)
------------------	-------------------------

OUTPUT SPECIFICATION :

Relay	2 Nos.
Relay Type	NO-C-NC, NO-C
Rating	5A,250V AC / 30V DC

AUXILIARY SUPPLY :

Supply Voltage	100 To 270 V AC,50/60Hz
Power Consumption (VA Rating)	3VA @ 230 VAC MAX

ENVIRONMENT CONDITION:

Operating Temp.	0°C to 55°C
Relative Humidity	UP to 95% RH (non-condensing)
Protection Level (As per request)	IP-65 (Front side) As per IS/IEC 60529 : 2001

MECHANICAL DIMENSION

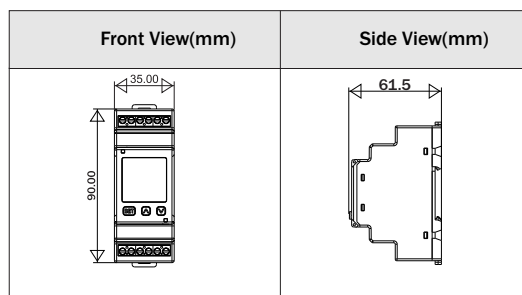

TERMINAL CONNECTION

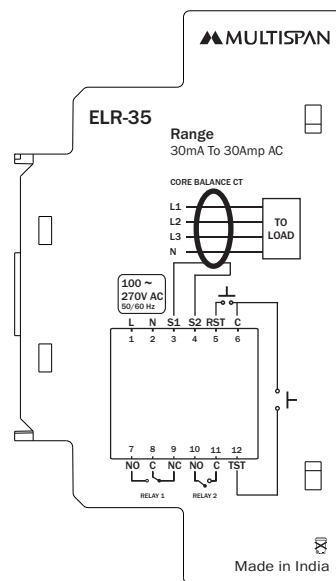

KEY OPERATION

FUNCTION	KEY PRESS
OPERATION MODE	
To Enter in Parameter Setting	SET For 3 sec
To Enter in Test Mode	▲ For 5 sec
To Reset the Relay Contact Manually After Tripping	▼ For 2 sec
PARAMETER SETTING MODE	
To set parameter value	SET
To increment parameter value.	▲
To decrement parameter value.	▼
Set parameter to be save & exit.	SET



SAFETY PRECAUTION

All safety related codifications, symbols and instructions that appear in this operating manual or on the equipment must be strictly followed to ensure the safety of the operating personnel as well as the instrument.

If all the equipment is not handled in a manner specified by the manufacturer, it might impair the protection provided by the equipment.



Read complete instructions prior to installation and operation of the unit.



WARNING : Risk of electric shock.

MAINTENANCE

1. The equipment should be cleaned regularly to avoid blockage of ventilating parts.
2. Clean the equipment with a clean soft cloth. Do not use isopropyl alcohol or any other cleaning agent.
3. Fusible resistor must not be replaced by operator.

WARNING GUIDELINES



WARNING : Risk of electric shock.

1. To prevent the risk of electric shock, power supply to the equipment must be kept OFF while doing the wiring arrangement. Do not touch the terminals while power is being supplied.
2. To reduce electro magnetic interference, use wire with adequate rating and twists of the same of equal size shall be made with shortest connection.
3. Cable used for connection to power source, must have a cross section of 1mm or greater. These wires should have insulations capacity made of at least 1.5kV.
4. When extending the thermocouple lead wires, always use thermocouple compensation wires for wiring for the RTD type, use a wiring material with a small lead resistance (5Ω max per line) and no resistance differentials among three wires should be present.
5. A better anti-noise effect can be expected by using standard power supply cable for the instrument.

INSTALLATION GUIDELINES

1. This equipment, being built-in-type, normally becomes a part of main control panel and in such case the terminals do not remain accessible to the end user after installation and internal wiring.
2. Do not allow pieces of metal, wire clippings, or fine metallic fillings from installation to enter the product or else it may lead to a safety hazard that may in turn endanger life or cause electrical shock to the operator.
3. Circuit breaker or mains switch must be installed between power source and supply terminal to facilitate power 'ON' or 'OFF' function. However this mains switch or circuit breaker must be installed at convenient place normally accessible to the operator.
4. Use and store the instrument within the specified ambient temperature and humidity ranges as mentioned in this manual.

MECHANICAL INSTALLATION GUIDELINES

1. Prepare the panel cutout with proper dimensions as shown above.
2. Fit the unit into the panel with the help of clamp given.
3. The equipment in its installed state must not come in close proximity to any heating source, caustic vapors, oil steam, or other unwanted process Byproducts.
4. Use the specified size of crimp terminal (M3.5 screws) to wire the terminal block. Tightening the screws on the terminal block using the tightening torque of the range of 1.2 N.m.
5. Do not connect anything to unused terminals.

PARAMETER SETTING

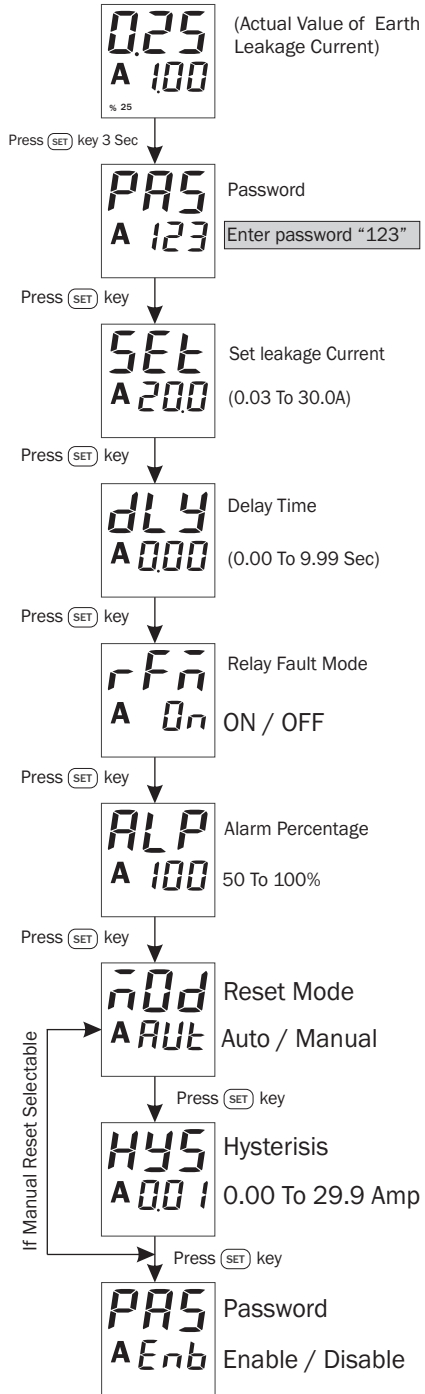

TEST MODE

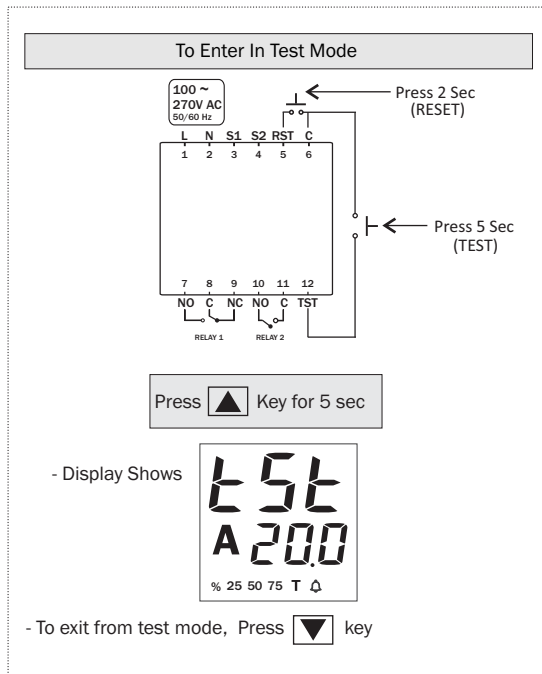

NOTE :
 Relay Fault mode select only for trip relay and alarm continuously ON for alarm condition
 Alarm Relay Hysteresis is 10% of set leakage current value.

RESET FUNCTION

To Reset the Relay Contact after tripping two modes are given.

1) Auto Reset

Faulty Condition relay mode = OFF
 Trip Set Point = 2.000 Amp
 Hysteresis = 0.100 Amp

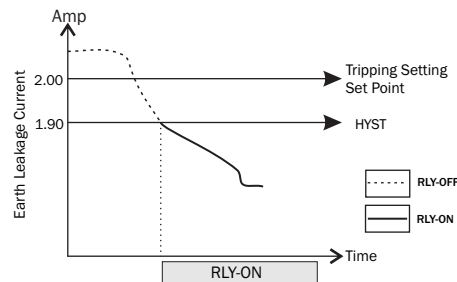

2) Manual Reset

NOTE: When Leakage Current < Setpoint

Press ▼ Key For 2 Sec.

TRIP FUNCTION

Faulty Condition relay mode = OFF

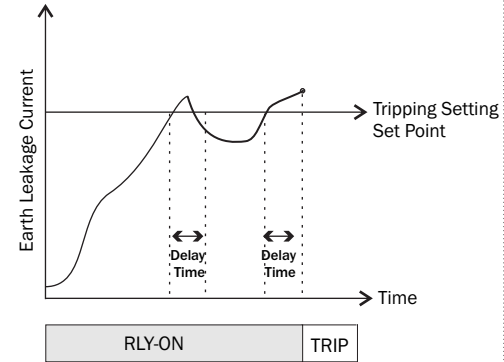

LED STATUS INDICATION

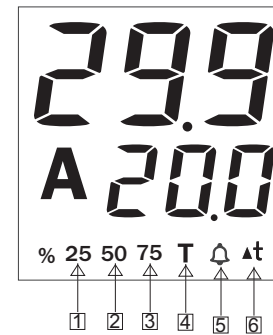

1) 25% LED	
Leakage Current ≥ 25%	LED Continuously ON
2) 50% LED	
Leakage Current ≥ 50%	LED Continuously ON
3) 75% LED	
Leakage Current ≥ 75%	LED Continuously ON
4) T (TRIP) LED	
Control Output Indication (ON/OFF)	
5) Δ (ALARM) LED	
Alarm Indication (ON/OFF)	
6) Δt (Time) LED	
Delay Time Run indication	

Specifications are subject to change, since development is a continuous process. So for more updated operating information and Support, please contact us. Ver:191201