

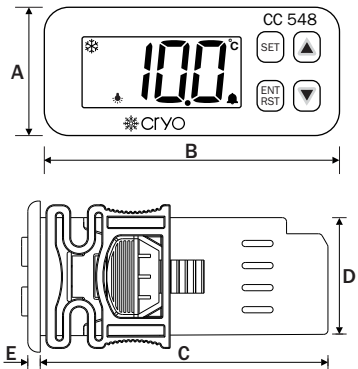

TECHNICAL SPECIFICATION

Model	CC-548
Display	3 Digit 0.62" 7 Segment RED / WHITE Display
Size (mm)	37 (H) x 78 (W) x 70 (D) mm
Panel Cutout	30 X 71 mm
Input	NTC Thermistor Pulse Input
Output	2 Relay, (NO-C-NC) 1st Relay For Compressor 20A (Resistive load) 2nd Relay for Alarm & Door EA (Resistive load)
Range	-50.0°C To 99.9°C
Power Supply	230V AC,50/60Hz,Approx 3VA
Operating Temperature	0°C To 55°C
Relative Humidity	Up to 95% RH Non Condensing

MECHANICAL INSTALLATION



MODEL	DIMENSIONS
A	37mm
B	78mm
C	70mm
D	29mm
E	3mm

Process Value

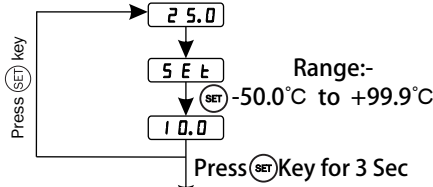

NOTE

- Press **SET** Key for go into the parameter
- Press **▲** & **▼** to change the parameter
- Press **ENT/ RST** key for exit from the program
- Press **ENT/ RST** key to reset the Alarm Relay when Alarm condition Occurs
- If No key is Pressed, Menu will Automatically exit after 15 SEC. with saving.
- LL :- Last Low Temperature
- LH :- Last High Temperature
- Press & hold **▲** Key for 2 Sec , then after instrument Will display LL temperature (last low temperature) for 4 Sec, then after LH temperature (last high temperature) for next 4 Sec after words instrument will come out of logmode and will display current temperature
- When the instrument is in log mode , one can reset LL-LH by press and hold set key for 2 Sec.

F2	Set High Temperature (HT) Range : LT to 99.9°C DEFAULT SETTING : 99.9°C	E1	Compressor Relay Status in case of probe failure Parameter : 0- Compressor OFF , 1- Compressor ON, 2- Compressor Perform Duty Cycle DEFAULT SETTING : 2
F3	Set Low Temperature (LT) Range : -50.0°C to HT DEFAULT SETTING : -50.0°C	Cn	Compressor relay OFF Time (Note : E1=2) Range : 1 Minute to 99 Minute DEFAULT SETTING : 4 MINUTE
H5	To Set Maximum set point limit. (LS + 1) Range : -50.0° to 99.9°C DEFAULT SETTING : 99.9°C	Cy	Compressor relay ON Time (Note : E1=2) Range : 1 Minute to 99 Minute DEFAULT SETTING : 10 MINUTE
L5	To Set Minimum set point limit. (HS - 1) Range : -50.0° to 99.9°C DEFAULT SETTING : -50.0°C	dD	To set Digital input status (After 10 Sec) 0 :-When it is close, contact healthy 1 :-When it is open, contact healthy DEFAULT SETTING : 0
F4	Temperature Difference to restart compressor relay (Hysteresis) Range : 0.1° to 20.0°C DEFAULT SETTING : 3.0°C	dI	To active or deactivate Digital input indication 0 :-Digital input disabled 1 :-Digital input enabled (auto reset) (After 5 Sec) 2 :-Digital input enabled (manual reset) DEFAULT SETTING : 0
F5	Probe Calibration (Offset) Range : -9.0° to 9.0°C -DEFAULT SETTING : 0.0° C	dP	To Set Decimal Point Yes / No DEFAULT SETTING : YES
F6	Time Delay between Compressor Relay Restart Range : 0 to 999 Minute DEFAULT SETTING : 3 MINUTE	tU	To Set Temperature Unit °C/°F DEFAULT SETTING : °C
0t	To set Minimum ON Time for Compressor Range : 0 to 20 Min DEFAULT SETTING : 0 Min	F5t	To restore Factory set parameter Yes / No DEFAULT SETTING : NO
F7	To set the Alarm Delay Time (IF AL = 1,2,3) Range : 0 to 99 Minute DEFAULT SETTING : 20 Minute	PSU	To set Password 0 : Disable, 1 : Enable DEFAULT SETTING : 0 If Select 1 then Password is 39 Password is Appear before programming menu
LP	To Lock Keypad 0 : Keypad unlocked , 1 : Keypad Lock DEFAULT SETTING : 0		
AL	Alarm Enable/Disable 0 : Alarm Relay OFF 1 : Alarm ON HT,LT,OPN, Door fault, 2 : Alarm ON HT,OPN, Door fault , 3 : Alarm ON LT,OPN, Door fault , DEFAULT SETTING : 2		
A3	To change relay polarity 0 :-Alarm relay will activate at NO 1 :-Alarm relay will activate at NC DEFAULT SETTING : 0		
A4	To set compressor status when HT fault 0 :-Compressor will be off 1 :-No action for compressor DEFAULT SETTING : 0		

WIRING DIAGRAM

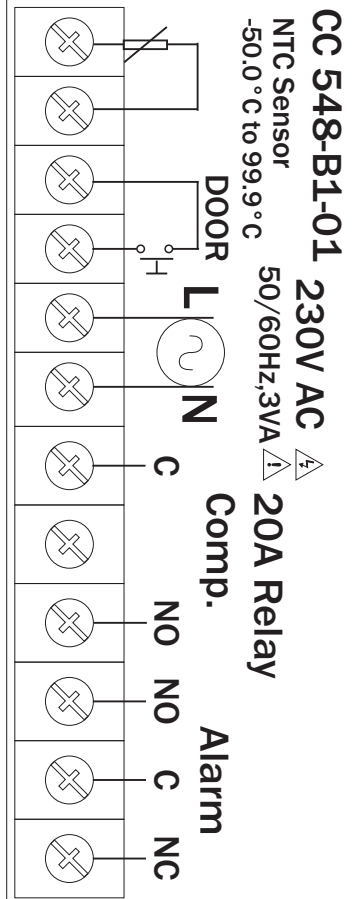

Installation Guidelines

- 1) This equipment, being built-in-type, normally becomes a part of main control panel and such in case the terminals do not remain accessible to the end user after installation and internal wiring.
- 2) Do not allow pieces of metal, wire clippings, or fine metallic fillings from installation to enter the product or else it may lead to a safety hazard that may in turn endanger life or cause electrical shock to the operator.
- 3) Circuit breaker or mains switch must be installed between power source and supply terminal to facilitate power 'ON' or 'OFF' function. However this mains switch or circuit breaker must be installed at convenient place normally accessible to the operator.
- 4) Use and store the instrument within the specified ambient temperature and humidity ranges as mentioned in this manual.

Maintenance

- 1) The equipment should be cleaned regularly to avoid blockage of ventilating parts.
- 2) Clean the equipment with a clean soft cloth. Do not use isopropyl alcohol or any other cleaning agent.
- 3) Fusible resistor must not be replaced by operator.

WIRING DIAGRAM

CC 548-B1-01

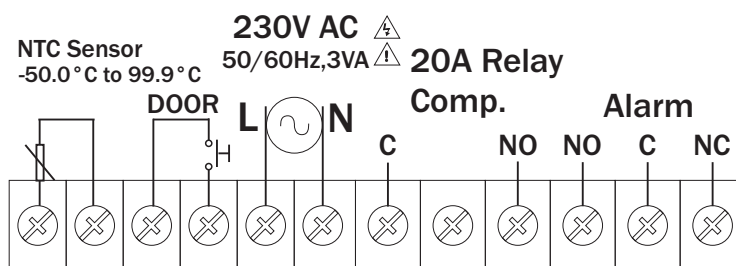

OPERATING MANUAL COOLING CONTROLLER

Factory Set Data		
Parameter	DP = Yes	DP = No
Hysteresis	3.0	3
Time Delay	3 min	3 min
Alarm Delay Time	20 Min	20 Min
Alarm Enable / Disable	2	2
Set Low Temp.	-50.0°C	-50°C
Set High Temp.	99.9°C	99°C
Set Low Setpoint Limit.	-50.0°C	-50°C
Set High Setpoint Limit.	99.9°C	99°C
Offset	0.0°C	0°C
Open	Duty Cycle	Duty Cycle
OT	0	0
A4	0	0
DO	0	0
Di	0	0

Setpoint, DP selection, A3 and Temperature will not change, When you restore the factory data.

• Mechanical Installation Guideline

- 1) Prepare the panel cutout with proper dimensions as show above.
- 2) Fit the unit into the panel with the help of clamp given.
- 3) The equipment in its installed state must not come in close proximity to any heating source, caustic vapors, oils steam, or other unwanted process by products.
- 4) Use the specified size of crimp terminal (M3.5 screws) to wire the terminal block. Tightening the screws on the terminal block using the tightening torque of the range of 1.2 N.m.
- 5) Do not connect anything to unused terminals.

Safety Precautions

All safety related codifications, symbols and instructions that appear in this operating manual or on the equipment must be strictly followed to ensure the safety of the operating personnel as well as the instrument.

If all the equipment is not handled in a manner specified by the manufacturer, it might impair the protection provided by the equipment .

=> Read complete instructions prior to installation and operation of the unit.

⚠ WARNING : Risk of electric shock.

Warning Guidelines

- 1) To prevent the risk of electric shock power supply to the equipment must be kept OFF while doing the wiring arrangement. Do not touch the terminals while power is being supplied.
- 2) To reduce electro magnetic interference, use wire with adequate rating and twists of the same of equal size shall be made with shortest connection.
- 3) Cable used for connection to power source, must have a cross section of 1mm or greater. These wires should have insulations capacity made of at least 1.5kV.
- 4) When extending the thermocouple lead wires, always use thermocouple compensation wires for wiring for the RTD type, use a wiring material with a small lead resistance (5Ω max per line) and no resistance differentials among three wires should be present.
- 5) A better anti-noise effect can be expected by using standard power supply cable for the instrument.



Temperature & Humidity Controllers

Designed for Refrigeration & HVAC

A wide range of controllers for managing various refrigeration applications.

A brand by **MULTISPAN**

Product improvement and upgrade is a constant procedure. Ver: 2208