

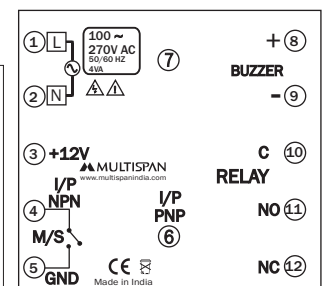

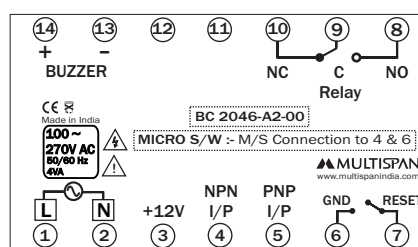
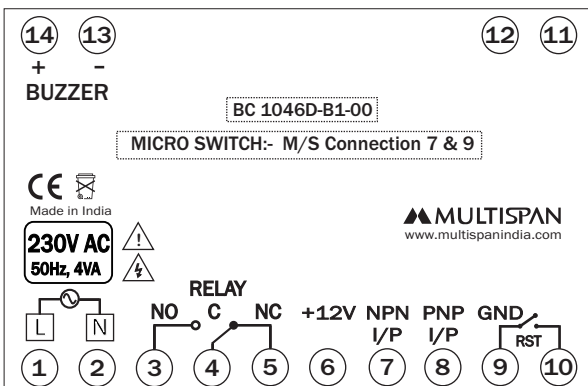

Technical Specification

Model	BC-1046D	BC-2046	BC-445
Display	UPPER:- 6 Digit 7 seg 0.56", red LED Display LOWER:- 4 Digit 7 seg 0.4", green LED Display	UPPER:- 6 Digit 7 seg 0.56", red LED Display LOWER:- 4 Digit 7 seg 0.4", green LED Display	UPPER:- 5 Digit 7 seg 0.3", red LED Display LOWER:- 4 Digit 7 seg 0.3", green LED Display
Size(HXWXD)	96 X 96 X 43 mm	72 X 72 X 45 mm	48 X 48 X 95 mm
Panel Cutout	92 X 92 mm	68 X 68 mm	44 X 44 mm
Output	1 Relay, 1C/O,230V AC,5A & Buzzer		
Power Supply	230V AC, 50 Hz, Approx 4VA	100 To 270V AC, 50/60 Hz, Approx 4VA	
Sensor	Proximity PNP/NPN (Selectable) & Micro Switch		
Memory	Nonvolatile		
Protection Level (As per request)	IP-65(Front side) AS per IS/IEC 60529:2001		
Operating Temperature	0 °C To 55 °C		
Relative Humidity	Up to 95% RH Non Condensing		

Connection Diagram



Key Operation

- 1) Press  Key to go next parameter.
- 2) Release the  Key, to save the set point.
- 3) Press  Key for manual reset of total count

For Program [H-1]:

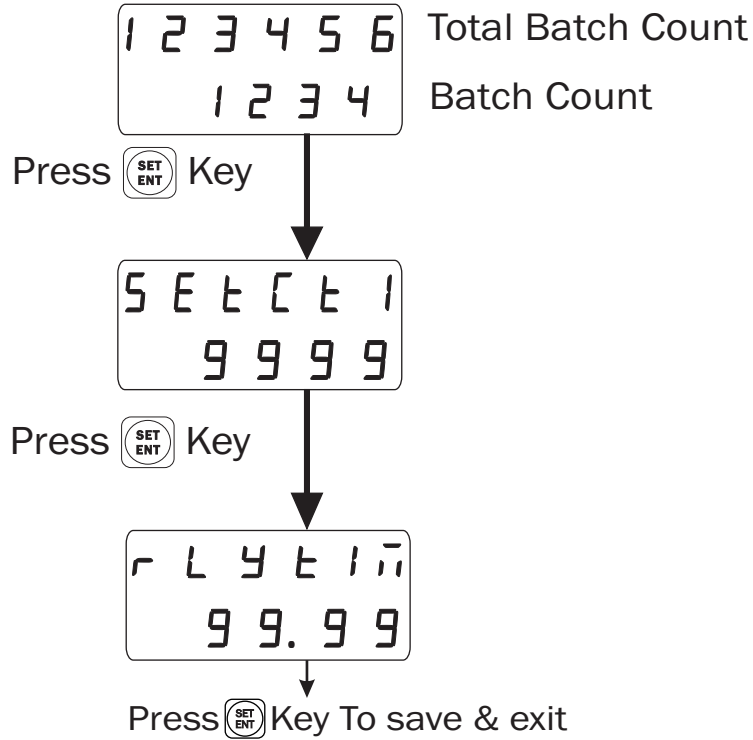

For Program [H-2]:

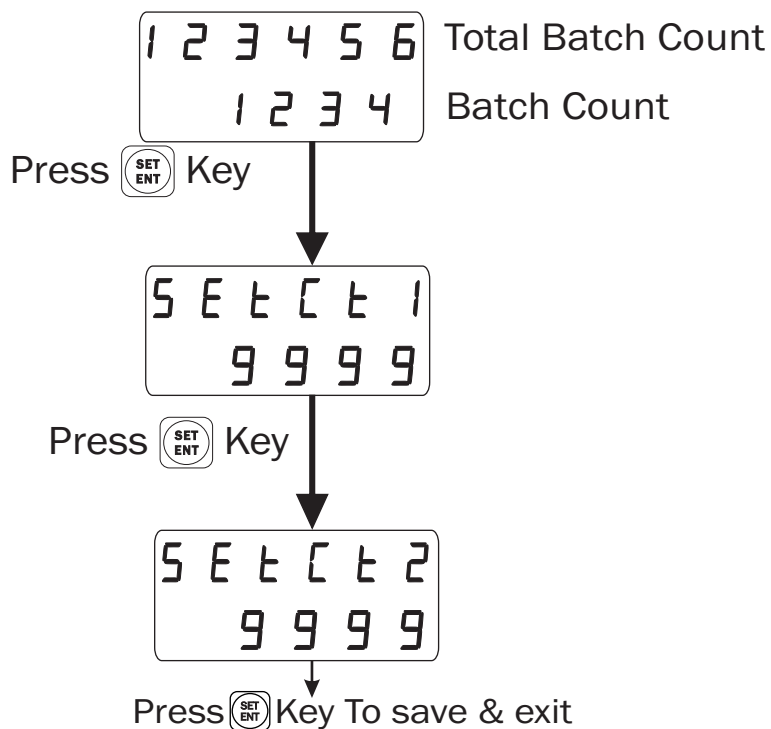

Working

[H-1

- * When set Count reaches at set value ,Relay and Buzzer will be ON.
- * Relay will stay on up to the set Time.
- * After completion of the set Time - both ,Relay and Buzzer will be OFF.
- * If the set time is 00.00 then Instrument will work in manual mode and user need to press Reset key to turn OFF Relay & Buzzer.

[H-2

Set Count - 1: Advance setting for batch Count.



Set Count - 2: Batch setting.

When it reaches to set count 1, Relay & Buzzer will be ON, & when it reaches to set count 2, Relay Buzzer will be OFF & Batch Count will be zero.

Always set the value of set 1 less then set 2.

Note:

Press  key and power on the instrument Display will show parameters 'SLOW'."MEDIUM" & "FAST"

	Set Speed Selection by Pressing  key
	SLOW : MAX RPM 500
	MEDIUM : MAX RPM 5000
	FAST: MAX RPM 15000
	Press  key to save the parameters

Procedure to set channel of program

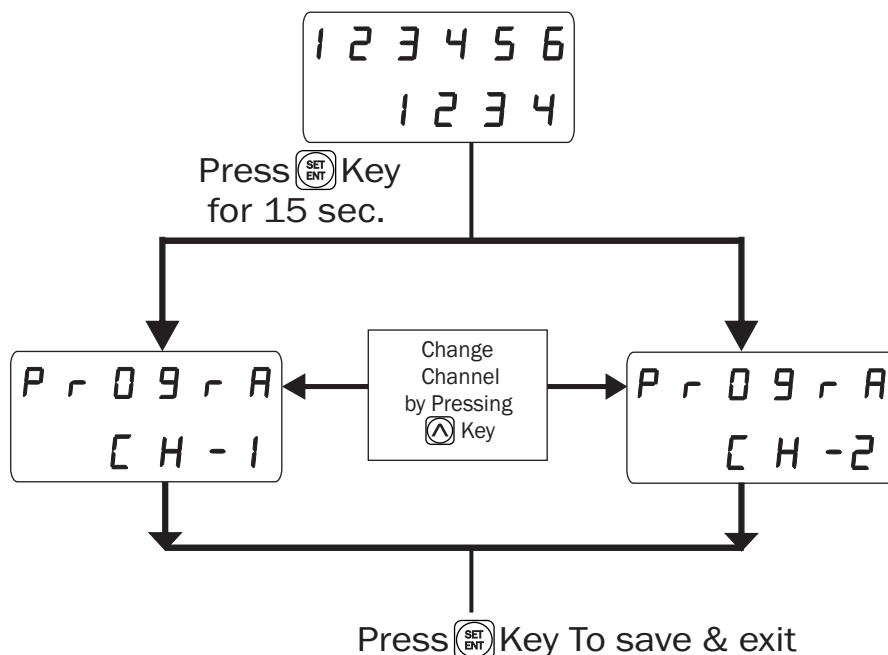

Safety Precautions

All safety related codifications, symbols and instructions that appear in this operating manual or on the equipment must be strictly followed to ensure the safety of the operating personnel as well as the instrument.

If all the equipment is not handled in a manner specified by the manufacturer, it might impair the protection provided by the equipment .

=> Read complete instructions prior to installation and operation of the unit.

 **WARNING** : Risk of electric shock.

Warning Guidelines

- 1) To prevent the risk of electric shock power supply to the equipment must be kept OFF while doing the wiring arrangement. Do not touch the terminals while power is being supplied.
- 2) To reduce electro magnetic interference, use wire with adequate rating and twists of the same of equal size shall be made with shortest connection.
- 3) Cable used for connection to power source, must have a cross section of 1mm^2 or greater. These wires should have insulations capacity made of at least 1.5kV.
- 4) A better anti-noise effect can be expected by using standard power supply cable for the instrument.

Installation Guidelines

- 1) This equipment, being built-in-type, normally becomes a part of main control panel and such in case the terminals do not remain accessible to the end user after installation and internal wiring.
- 2) Do not allow pieces of metal, wire clippings, or fine metallic fillings from installation to enter the product or else it may lead to a safety hazard that may in turn endanger life or cause electrical shock to the operator.
- 3) Circuit breaker or mains switch must be installed between power source and supply terminal to facilitate power 'ON' or 'OFF' function. However this mains switch or circuit breaker must be installed at convenient place normally accessible to the operator.
- 4) Use and store the instrument within the specified ambient temperature and humidity ranges as mentioned in this manual.

Mechanical Installation

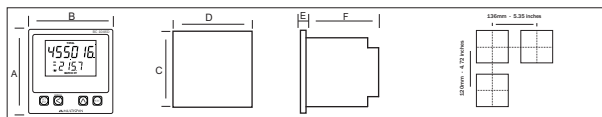
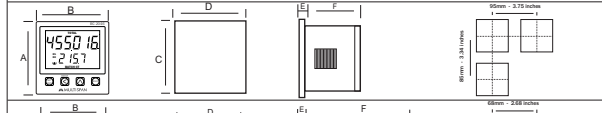
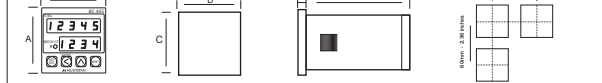
	<table border="1"> <thead> <tr> <th>MODEL</th> <th>A</th> <th>B</th> <th>C</th> <th>D</th> <th>E</th> <th>F</th> </tr> </thead> <tbody> <tr> <td>DIMENSIONS</td> <td>96mm</td> <td>96mm</td> <td>92mm</td> <td>92mm</td> <td>3mm</td> <td>43mm</td> </tr> </tbody> </table>	MODEL	A	B	C	D	E	F	DIMENSIONS	96mm	96mm	92mm	92mm	3mm	43mm
MODEL	A	B	C	D	E	F									
DIMENSIONS	96mm	96mm	92mm	92mm	3mm	43mm									
	<table border="1"> <thead> <tr> <th>MODEL</th> <th>A</th> <th>B</th> <th>C</th> <th>D</th> <th>E</th> <th>F</th> </tr> </thead> <tbody> <tr> <td>DIMENSIONS</td> <td>72mm</td> <td>72mm</td> <td>68mm</td> <td>68mm</td> <td>3mm</td> <td>45mm</td> </tr> </tbody> </table>	MODEL	A	B	C	D	E	F	DIMENSIONS	72mm	72mm	68mm	68mm	3mm	45mm
MODEL	A	B	C	D	E	F									
DIMENSIONS	72mm	72mm	68mm	68mm	3mm	45mm									
	<table border="1"> <thead> <tr> <th>MODEL</th> <th>A</th> <th>B</th> <th>C</th> <th>D</th> <th>E</th> <th>F</th> </tr> </thead> <tbody> <tr> <td>DIMENSIONS</td> <td>48mm</td> <td>48mm</td> <td>44mm</td> <td>44mm</td> <td>3mm</td> <td>95mm</td> </tr> </tbody> </table>	MODEL	A	B	C	D	E	F	DIMENSIONS	48mm	48mm	44mm	44mm	3mm	95mm
MODEL	A	B	C	D	E	F									
DIMENSIONS	48mm	48mm	44mm	44mm	3mm	95mm									

- 1) Prepare the panel cutout with proper dimensions as show above.
- 2) Fit the unit into the panel with the help of clamp given.
- 3) The equipment in its installed state must not come in close proximity to any heating source, caustic vapors, oils steam, or other unwanted process by products.
- 4) Use the specified size of crimp terminal (M3.5 screws) to wire the terminal block. Tightening the screws on the terminal block using the tightening torque of the range of 1.2 N.m.
- 5) Do not connect anything to unused terminals.

Maintenance

- 1) The equipment should be cleaned regularly to avoid blockage of ventilating parts.
- 2) Clean the equipment with a clean soft cloth. Do not use isopropyl alcohol or any other cleaning agent.
- 3) Fusible resistor must not be replaced by operator.

Product improvement and upgrade is a constant procedure.